

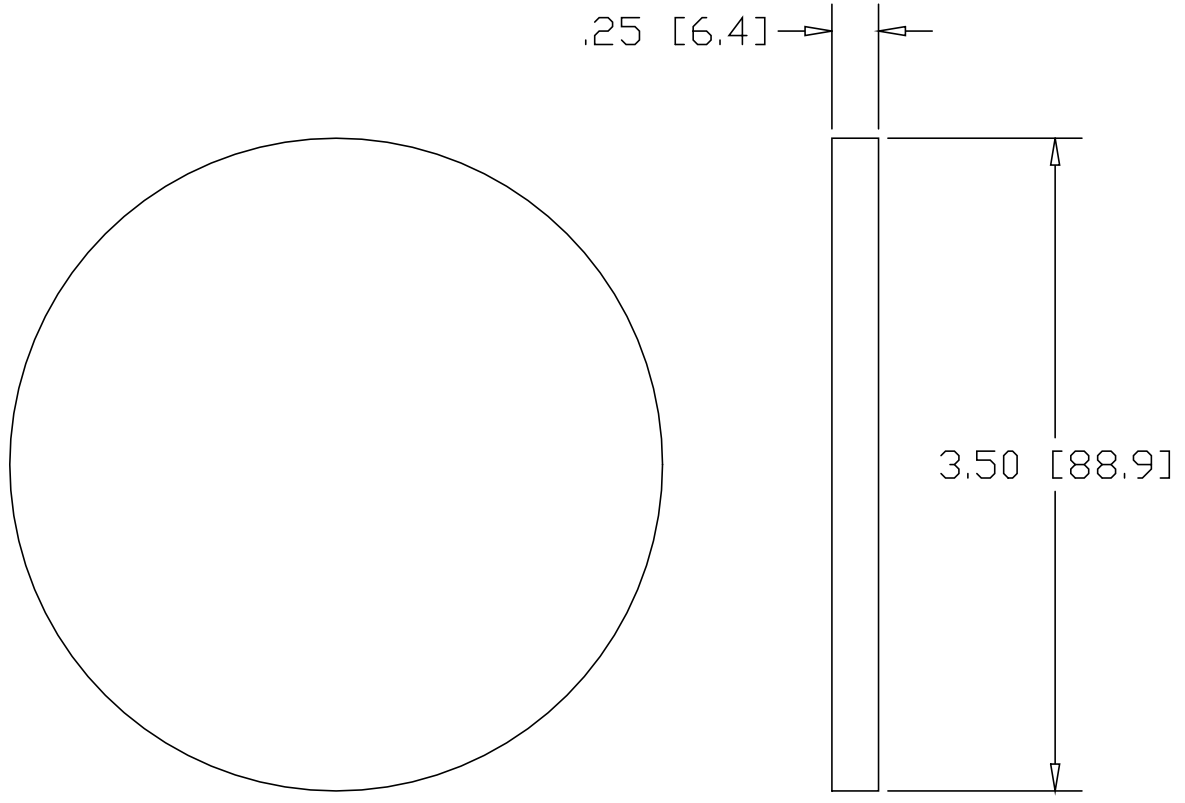

REV
SH
D173
DWG NO

REVISIONS			
REV	DESCRIPTION	DATE	APPROVED



INCHES[MILLIMETERS]

ALTERNATE MATERIAL	PART NUMBER
.250 (3003) ALUMINUM ASTM B209	D174
.250 (304) STAINLESS STEEL ASTM A240	D175
.250 (260) BRASS ASTM B19,B36	D176
.250 (280) MUNTZ METAL	D176M

PART NAME		3.50" OD TUBE SIZE TYPE-D WELD-ON DISK					
MATERIAL		.250 HRP&D STEEL ASTM A569					
DATE	11/20/98	 THE WAGNER COMPANIES R & B WAGNER, INC. AND J. G. BRAUN CO.					
DRAWN BY	RJF						
FINISH	MILL						
SIZE	A	WEIGHT	.7 LBS	PART NUMBER	D173	REV	