

REV  
SH  
1427A  
DWG NO

REVISIONS			
REV	DESCRIPTION	DATE	APPROVED

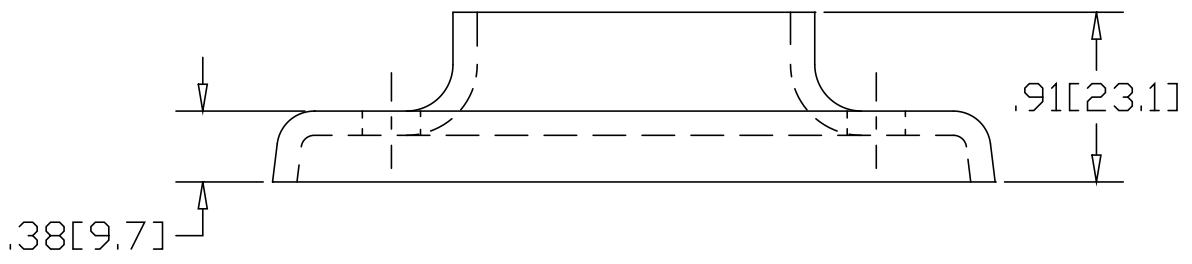
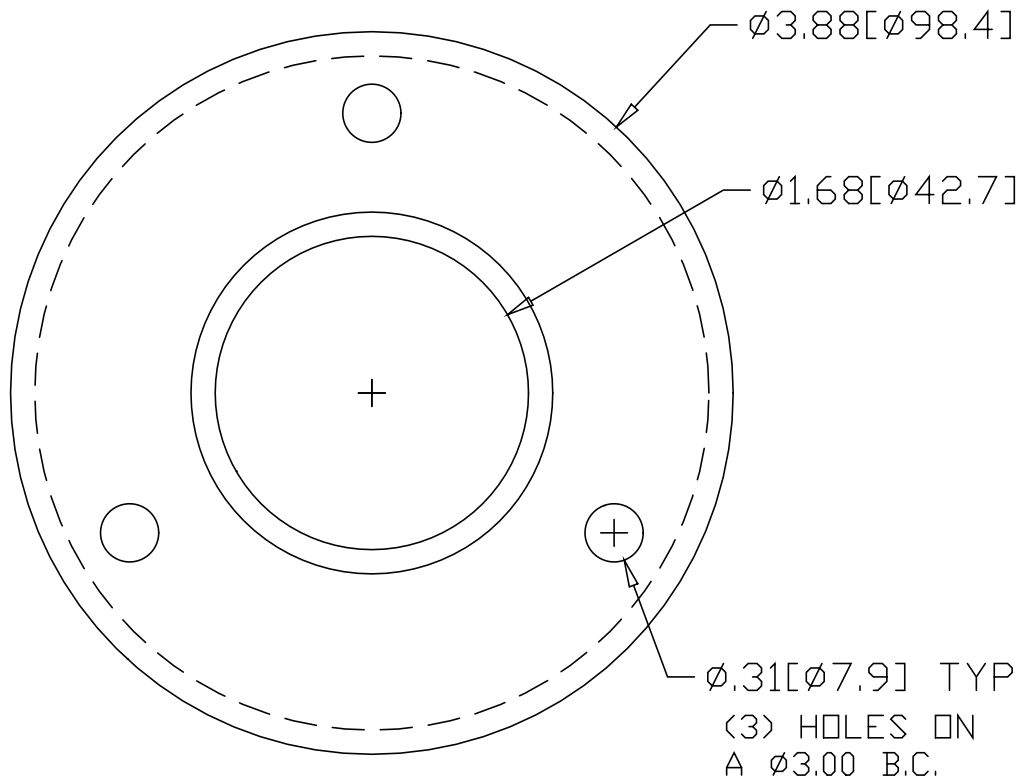

INCHES [MILLIMETERS]

\*USE WITH ANCHOR PLATE  
 #B1432 IN STEEL  
 #PLB1432 ZINC PLATED STEEL  
 #B1532 IN STAINLESS STEEL

ALTERNATE MATERIAL	PART NUMBER
.125 (3003) ALUMINUM ASTM B209	1467A
10 GA. (304) STAINLESS STEEL ASTM A240	1527A

PART NAME 1-1/4" PIPE HEAVY BASE FLANGE W/(3) HOLES			
MATERIAL 10 GA. HRP&D STEEL ASTM A569			
DATE 9/13/94			
DRAWN BY RJF			
FINISH MILL			
SIZE A	WEIGHT .50 LBS	PART NUMBER 1427A	REV