

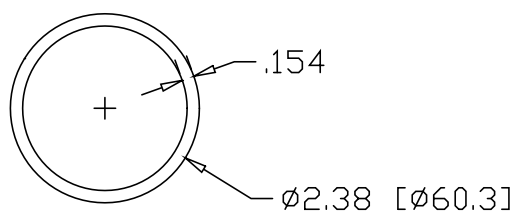

REV  
SH  
7189  
DWG NO

REVISIONS			
REV	DESCRIPTION	DATE	APPROVED

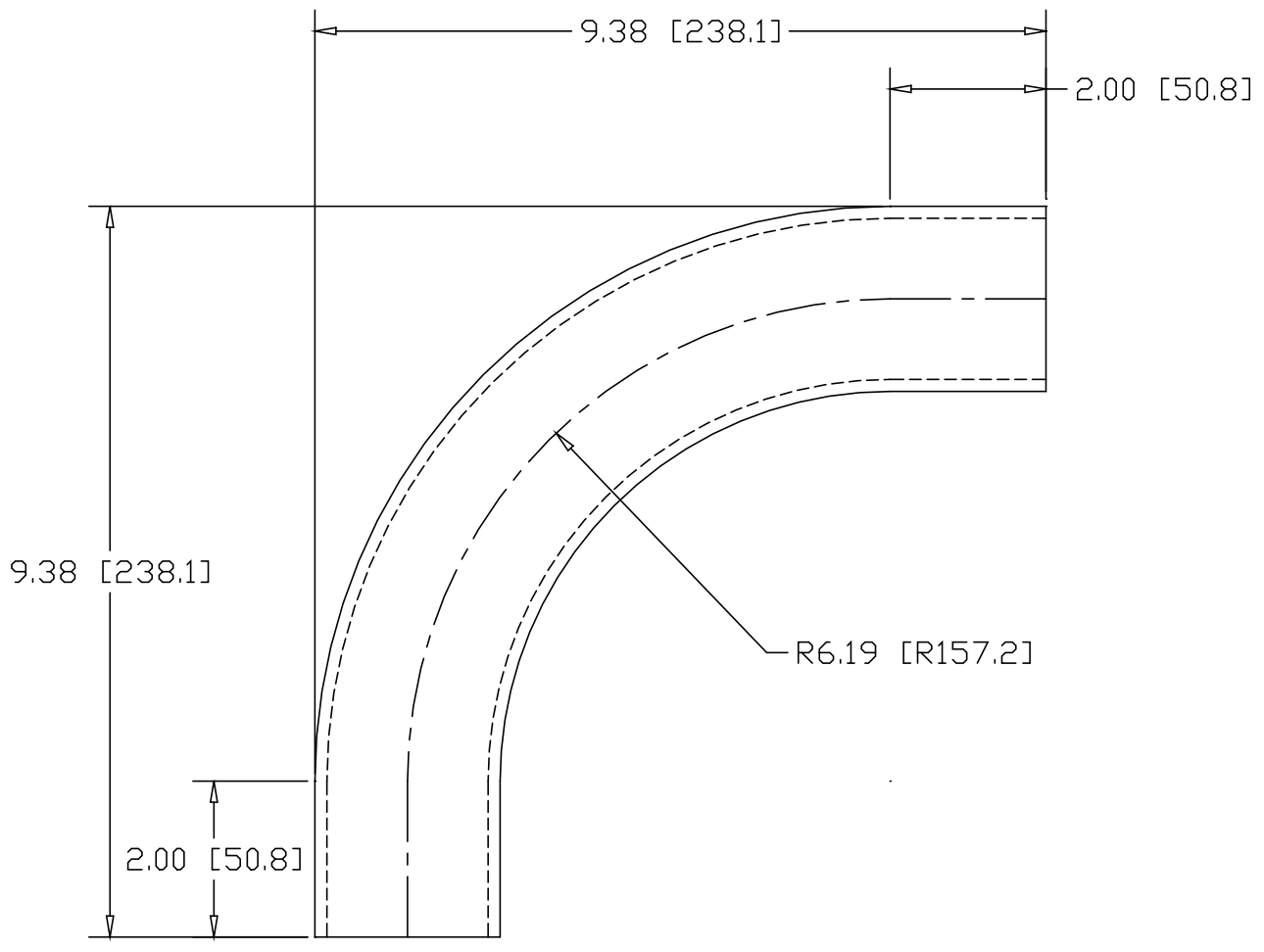

INCHES [MILLIMETERS]

ALTERNATE MATERIAL	PART NUMBER
2" SCH 40 (6063) ALUMINUM PIPE	7209
2" SCH 40 (304) STAINLESS STEEL PIPE	7229

PART NAME 2" PIPE SIZE 90° ELL X 5" I.R. W/ (2) 2" TANGENTS			
MATERIAL 2" SCH 40 A53 STEEL PIPE			
DATE 7/02/01		R & B WAGNER, INC.	
DRAWN BY JAH		SIZE A	WEIGHT 4.18 LBS
FINISH MILL			REV