

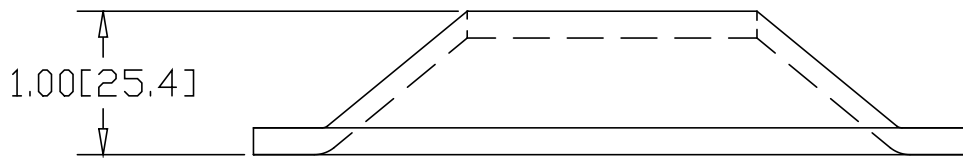

REV
SH
8051-NH
DWG NO

REVISIONS			
REV	DESCRIPTION	DATE	APPROVED

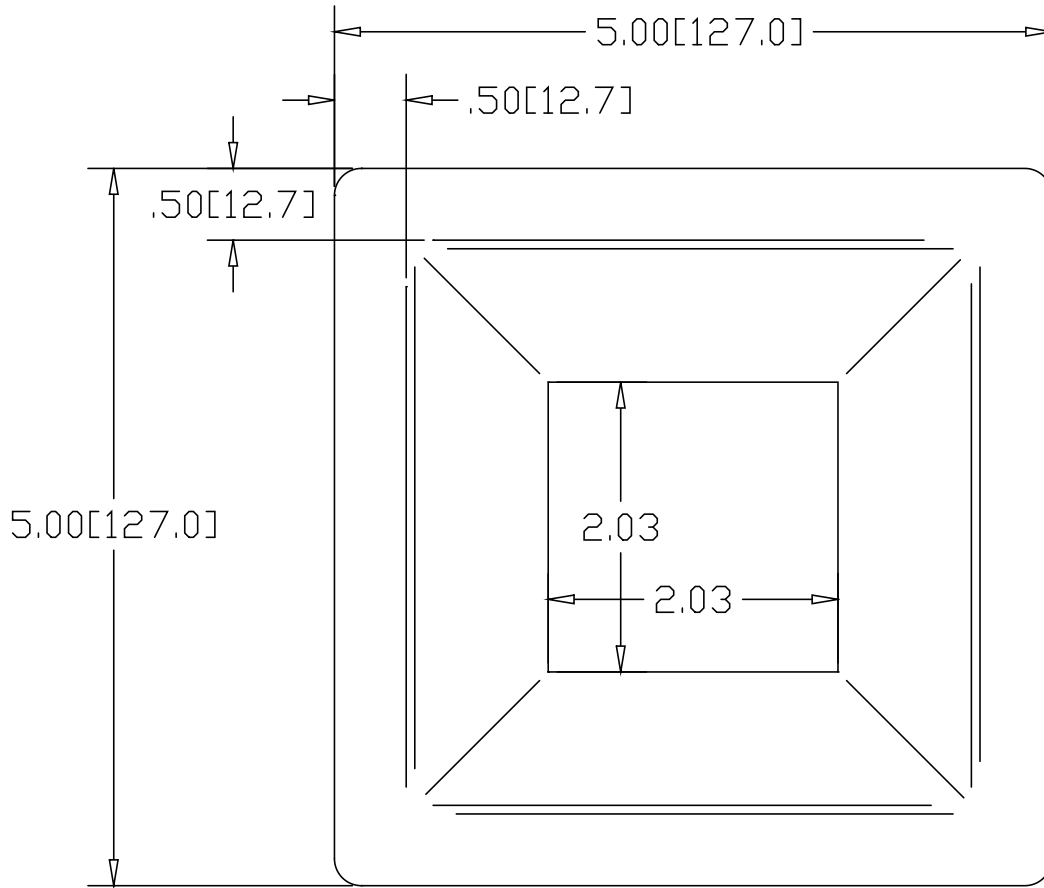

INCHES [MILLIMETERS]

ALTERNATE MATERIAL	PART NUMBER
.190 (3003) ALUMINUM ASTM B209	8052-NH

PART NAME		2" SQUARE TUBE FLANGE	
MATERIAL		7 GA. HRP&D STEEL ASTM A569	
DATE	6/12/96	 R & B WAGNER, INC.	
DRAWN BY	RJF		
FINISH	MILL	SIZE	A
		WEIGHT	1.2 LBS
		PART NUMBER	8051-NH
		REV	