

REV A
SH
DWG NO 1436

REVISIONS			
REV	DESCRIPTION	DATE	APPROVED
A	.92 WAS .96, .375 WAS .43	04/07/14	RJF

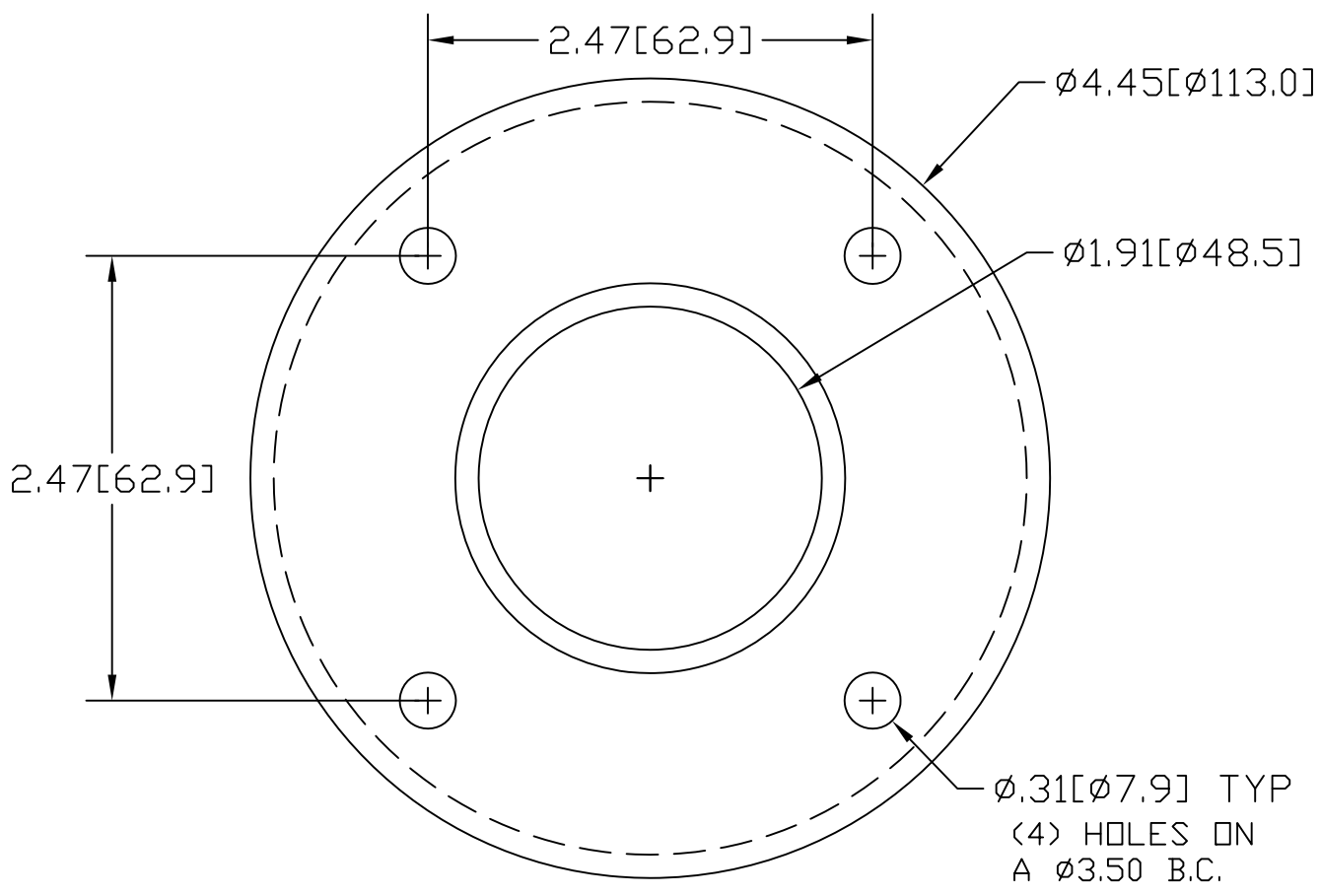

INCHES [MILLIMETERS]

*USE WITH ANCHOR PLATE
#B1440 IN STEEL
#PLB1440 ZINC PLATED STEEL
#B1540 IN STAINLESS STEEL

ALTERNATE MATERIAL	PART NUMBER
.125 (3003) ALUMINUM ASTM B209	1476
10 GA. (304) STAINLESS STEEL ASTM A240	1536

PART NAME 1-1/2" PIPE HEAVY BASE FLANGE W/(4) HOLES				
MATERIAL 10 GA. HRP&D STEEL ASTM A569				
DATE 9/13/94	 R & B WAGNER, INC.			
DRAWN BY RJF				
FINISH MILL	SIZE A	WEIGHT .64 LBS	PART NUMBER 1436	REV A