

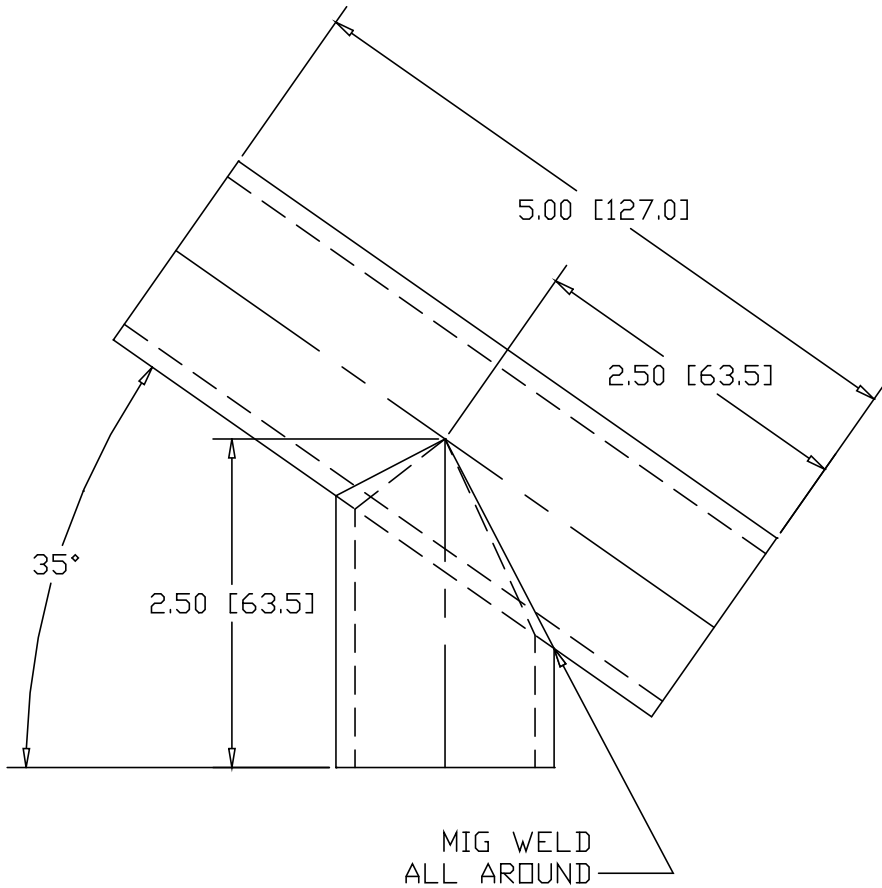

REV
SH
DWG NO 848-B

REVISIONS			
REV	DESCRIPTION	DATE	APPROVED



INCHES [MILLIMETERS]

PART NAME 1-1/4" PIPE 35 DEG. BEVELED TEE			
MATERIAL 1-1/4" SCH 40 STEEL PIPE			
DATE 3/24/09	 THE WAGNER COMPANIES R & B WAGNER, INC. AND J. G. BRAUN CO.		
DRAWN BY DGP			
FINISH MILL	SIZE A	WEIGHT .82	PART NUMBER 848-B
			REV

