

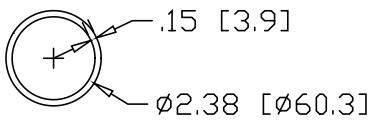

REV  
SH  
9363B  
DWG NO

REVISIONS			
REV	DESCRIPTION	DATE	APPROVED

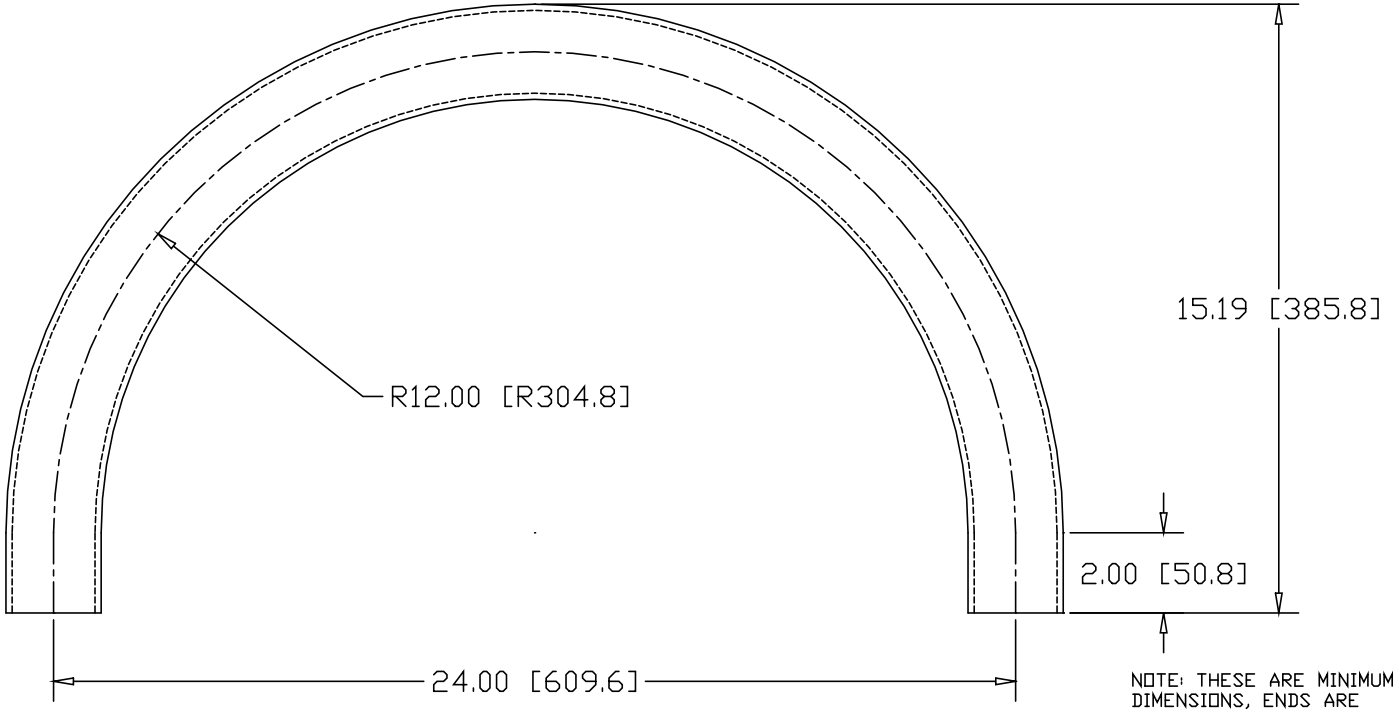

INCHES [MILLIMETERS]

ALTERNATE MATERIAL	PART NUMBER
2" SCH 40 (6063) ALUMINUM PIPE	9377B
2" SCH 40 (304) STAINLESS STEEL PIPE	9391B

PART NAME 2" PIPE SIZE 180° ELL X 10.81" I.R. W/ (2) 2" TANGENTS			
MATERIAL 2" SCH 40 A53 STEEL PIPE			
DATE 8/16/01		R & B WAGNER, INC.	
DRAWN BY JAH		PART NUMBER	9363B
FINISH MILL		SIZE A	WEIGHT 12.74 LBS