

2

1



B

B

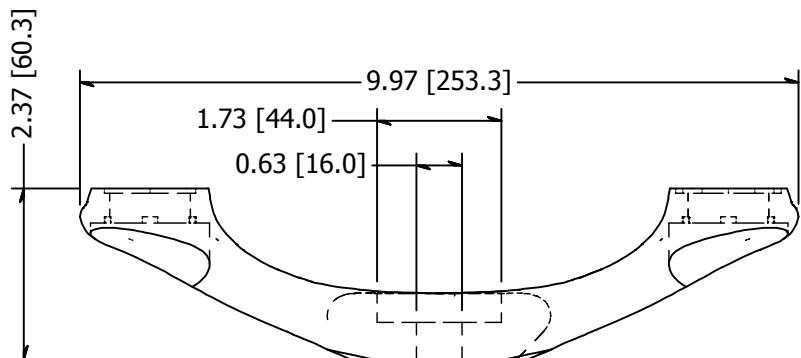

A

A

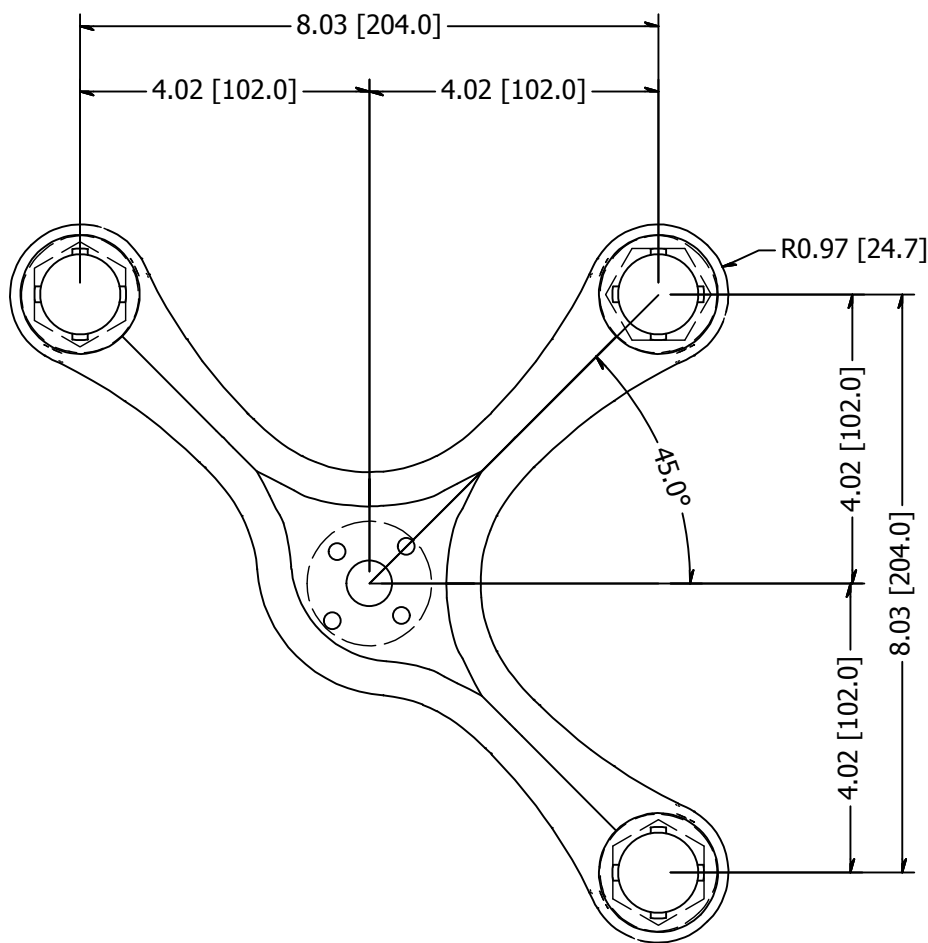

TOLERANCE UNLESS OTHERWISE NOTED, TOLERANCES TO CONFORM TO ES.03.011	CUT LENGTH:	FINISH:	DESCRIPTION: Spider, Stainless Steel, Sm Series, 200mm C/C 3 Point, Brushed Satin Finish, Grade 316	
		#4	MATERIAL:	MATERIAL DESC:
	DEVELOPED LENGTH:	WEIGHT:	Stainless Steel	316 Stainless Steel, Cast
	TOOL NUMBER:	4.17 lbmass	DATE: 9/27/2017	REV: -
		DRAWN BY: T. Kolbach	 10600 W Brown Deer Rd Milwaukee, WI 53224 COLLABORATIVE METALWORKS http://www.wagnercompanies.com/	
		PART NUMBER: LXSM3000		

2

1

