

REVISION HISTORY

REV	DESCRIPTION	DATE	APPROVED
1	2-1/2" Center Line	4/18/17	TLK

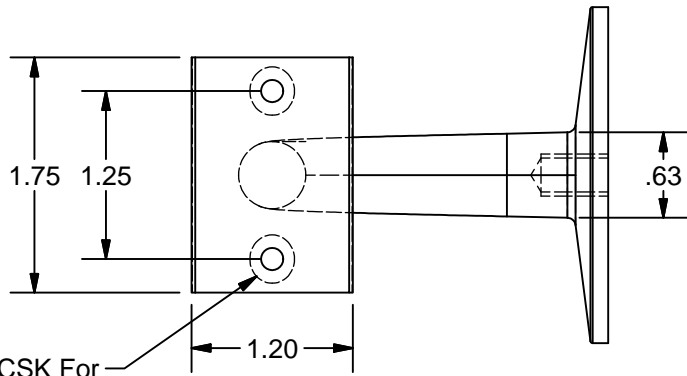

Drill Thru & CSK For #8 Flathead Screw 2 Places

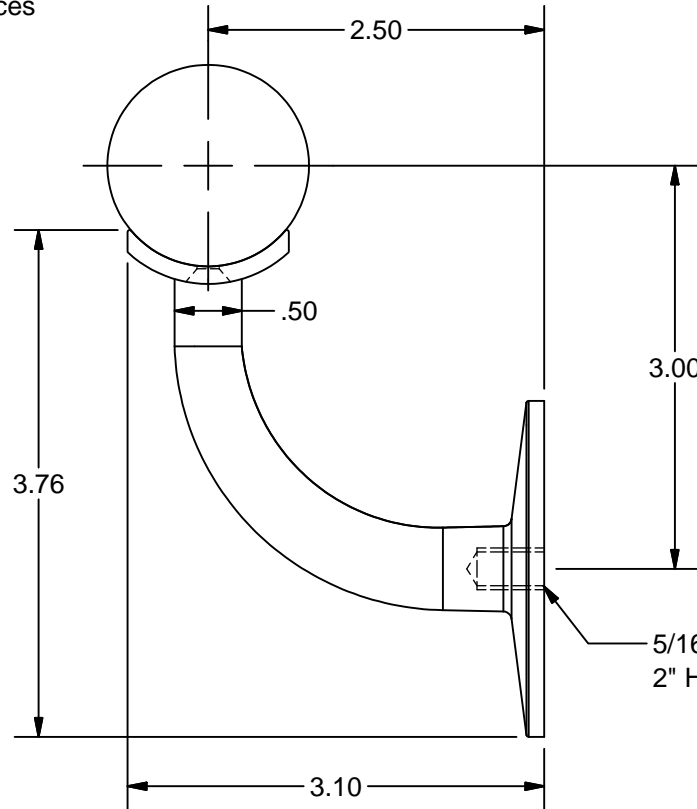
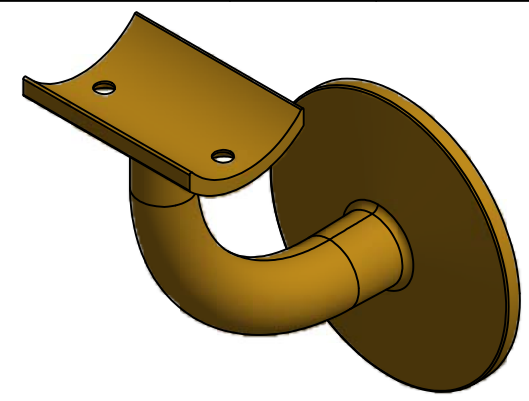

5/16-18 UNC - 2B x 1/2" For 2" Hanger Bolt

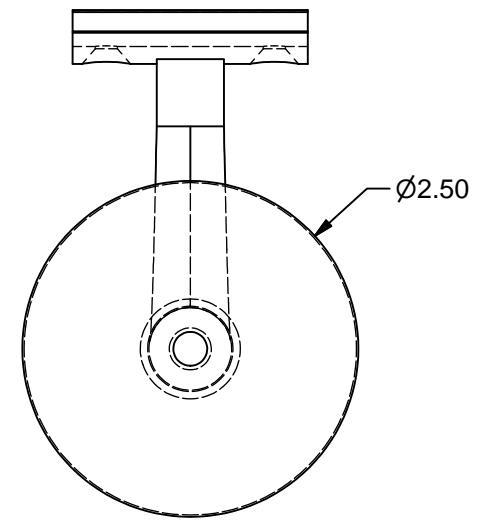

<p>TOLERANCE</p> <p>X.X..... = ± .060</p> <p>X.XX..... = ± .030</p> <p>X.XXX..... = ± .010</p> <p>XX°..... = ± 1°</p> <p>UNLESS OTHERWISE NOTED</p>	CUT LENGTH:	FINISH:	DESCRIPTION: Handrail Bracket, Brass, For 1.50 Inch Diameter Tube, 2.50 Inch From Wall To Center of Handrail. With 5/16-18 Threaded Hole	
		#7 Bright	MATERIAL:	MATERIAL DESC:
	DEVELOPED LENGTH:	WEIGHT:	DATE:	REV:
	TOOL NUMBER:	0.63 lbmass	4/18/2017	1
			DRAWN BY:	<p>WAGNER</p> <p>COLLABORATIVE METAL WORKS</p>
			T. Kolbach	
			PART NUMBER:	
			141535	

