

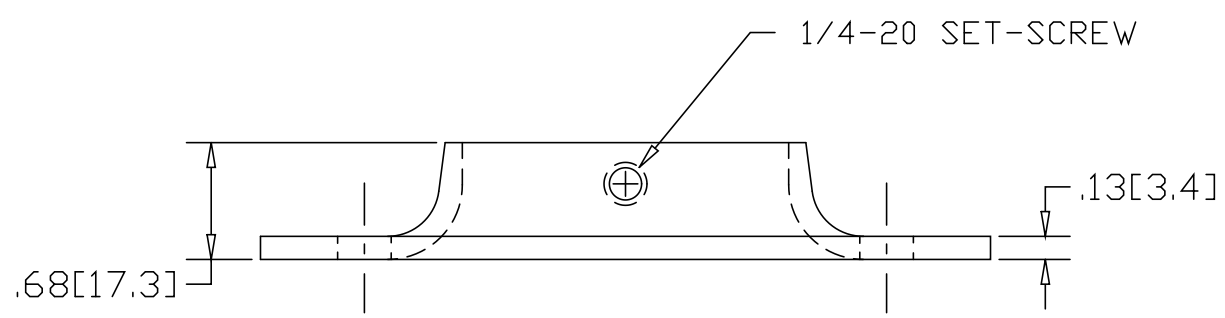

REV
SH
638A
DWG NO

REVISIONS			
REV	DESCRIPTION	DATE	APPROVED

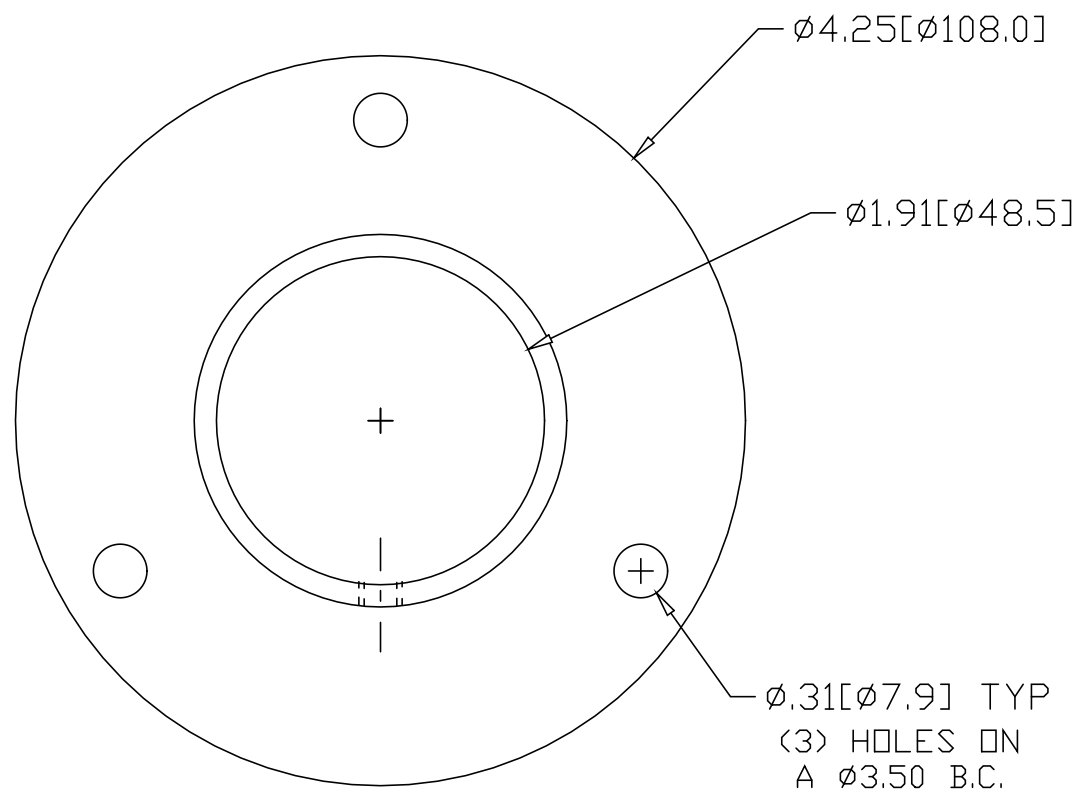

INCHES [MILLIMETERS]

ALTERNATE MATERIAL	PART NUMBER
.125 (3003) ALUMINUM ASTM B209	678A
10 GA. (304) STAINLESS STEEL ASTM A240	718A

PART NAME 1-1/2" FLAT BASE PIPE FLANGE W/(3) HOLES AND SET-SCREW			
MATERIAL 10 GA. HRP&D STEEL ASTM A-569			
DATE 1/7/99		R & B WAGNER, INC.	
DRAWN BY RJF		FINISH MILL	SIZE A
		PART NUMBER 638A	REV