

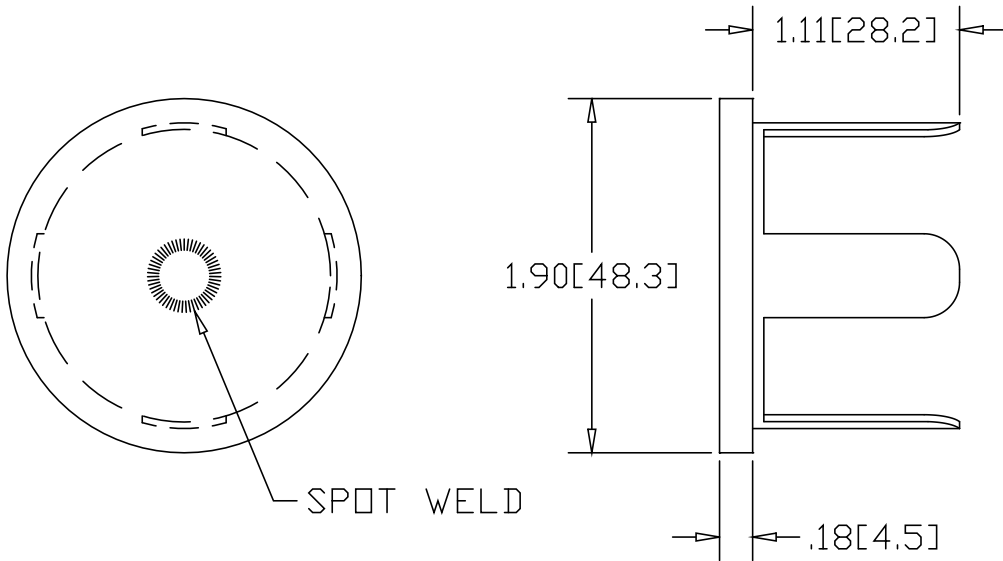

DWG NO 3287 SH REV

REVISIONS			
REV	DESCRIPTION	DATE	APPROVED

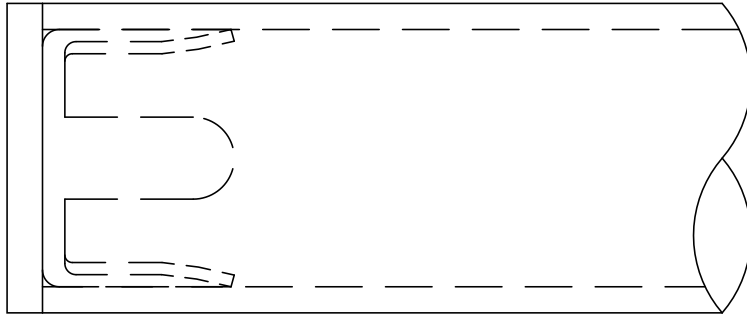
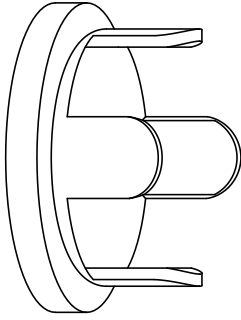

INCHES [MILLIMETERS]

ALTERNATE MATERIAL	PART NUMBER
.190 (3003) ALUMINUM ASTM B209	3292
7 GA. (304) STAINLESS STEEL ASTM A240	3287-SS

PART NAME 1-1/2" PIPE SIZE TYPE "E" DRIVE-ON DISK				
MATERIAL 7 GA. HRP&D STEEL ASTM A569				
DATE 3/28/95		<b>THE WAGNER COMPANIES</b> R & B WAGNER, INC. AND J. G. BRAUN CO.		
DRAWN BY RJF				
FINISH MILL	SIZE A	WEIGHT .20 LBS	PART NUMBER 3287	REV