

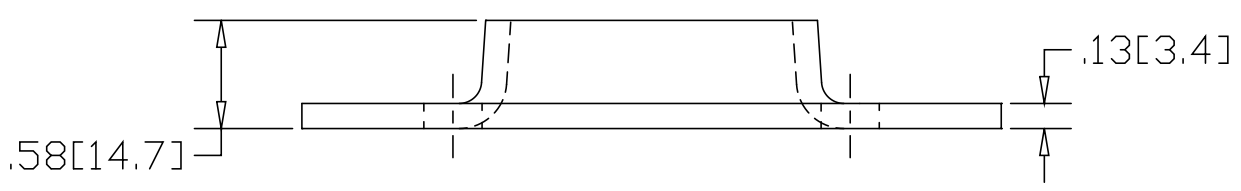

REV  
SH  
636T  
DWG NO

REVISIONS			
REV	DESCRIPTION	DATE	APPROVED

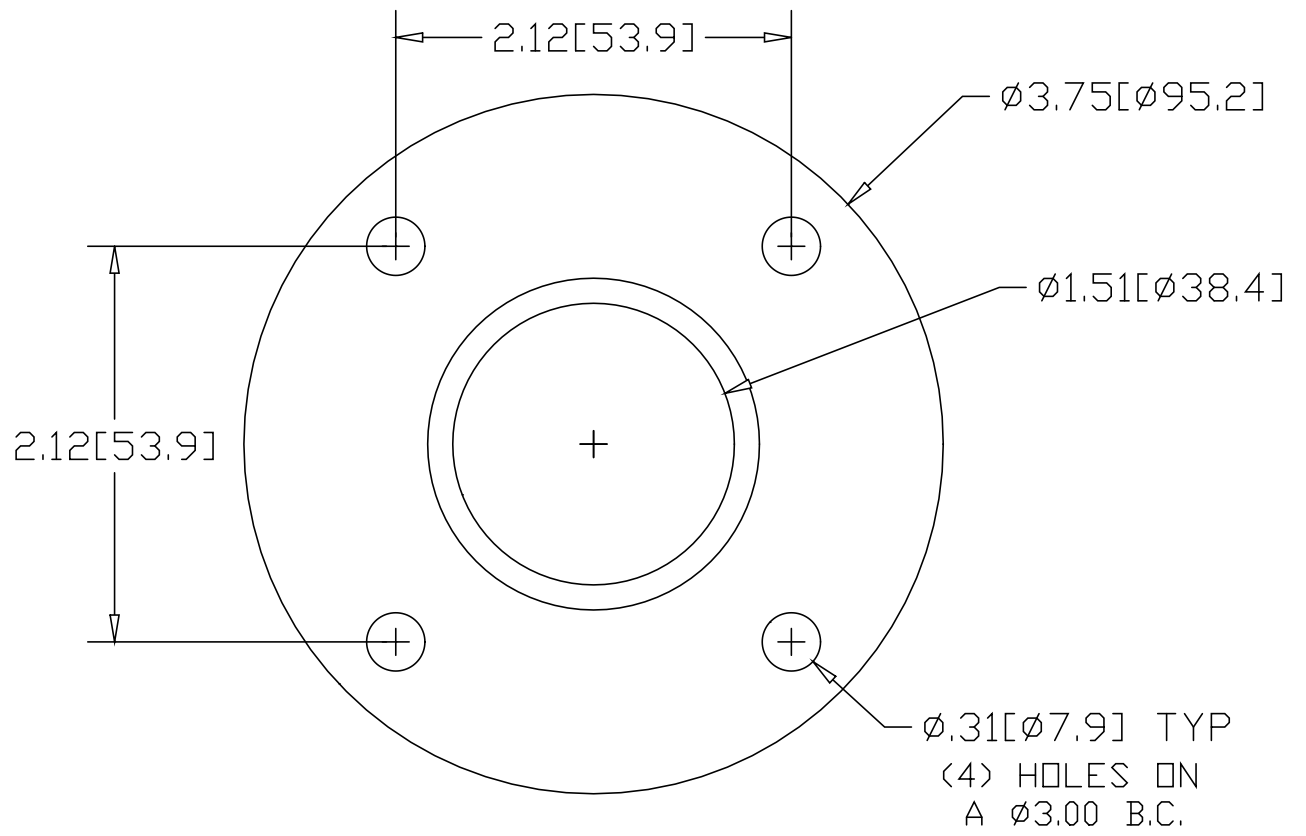

INCHES [MILLIMETERS]

ALTERNATE MATERIAL	PART NUMBER
.125 (3003) ALUMINUM ASTM B209	676T
10 GA. (304) STAINLESS STEEL ASTM A240	716T

PART NAME 1-1/2" O.D. TUBE FLAT BASE FLANGE W/(4) HOLES			
MATERIAL 10 GA. HRP&O STEEL ASTM A-569			
DATE 1/11/99		R & B WAGNER, INC.	
DRAWN BY RJF		SIZE A	WEIGHT .42 lbs
FINISH MILL			REV