

REVISIONS			
REV	DESCRIPTION	DATE	APPROVED

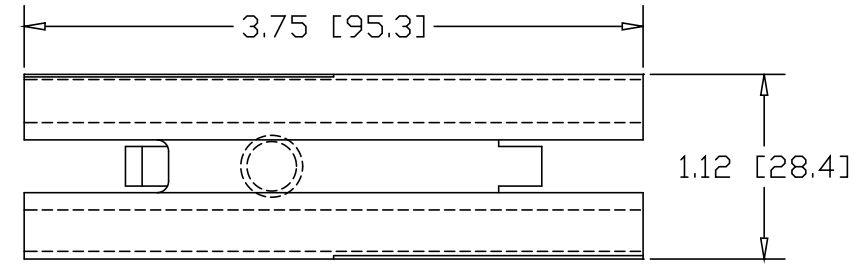

1.50" SQ X .188W TUBE

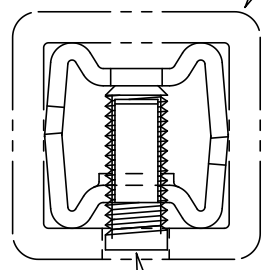

3/8-16 SOCKET HEAD SET-SCREW X 1" LG

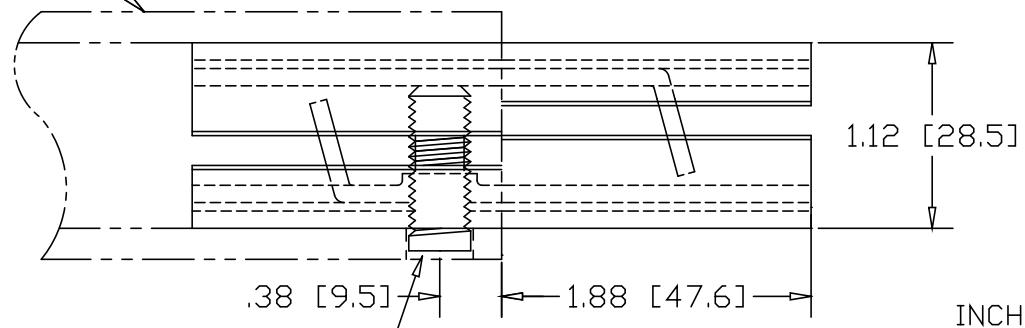

INCHES [MILLIMETERS]

DRILL ϕ .406 HOLE
.38" IN FROM END

ALTERNATE MATERIAL	PART NO.
12 GA. STEEL HOT DIP GALVANIZED	G3341-2
12 GA. STEEL ZINC PLATED	PL3341-2
.090 (3003) ALUMINUM ASTM B209	3344-2
.090 (304) STAINLESS STEEL ASTM A240	3347-2

PART NAME		1.50" SQ. .188W TUBE SINGLE-LOCK SPLICE-LOCK					
MATERIAL		12 GA. HRP&D STEEL ASTM A569					
DATE	9/25/01	 R & B WAGNER, INC.					
DRAWN BY	JAH						
FINISH	MILL						
SIZE	A	WEIGHT	.43 LBS	PART NUMBER	3341-2	REV	