

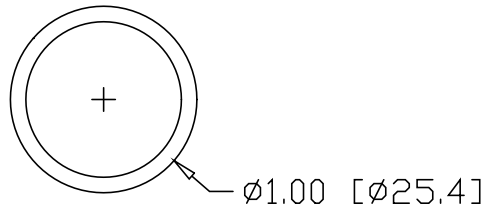

REV
SH
7812
DWG NO

REVISIONS			
REV	DESCRIPTION	DATE	APPROVED

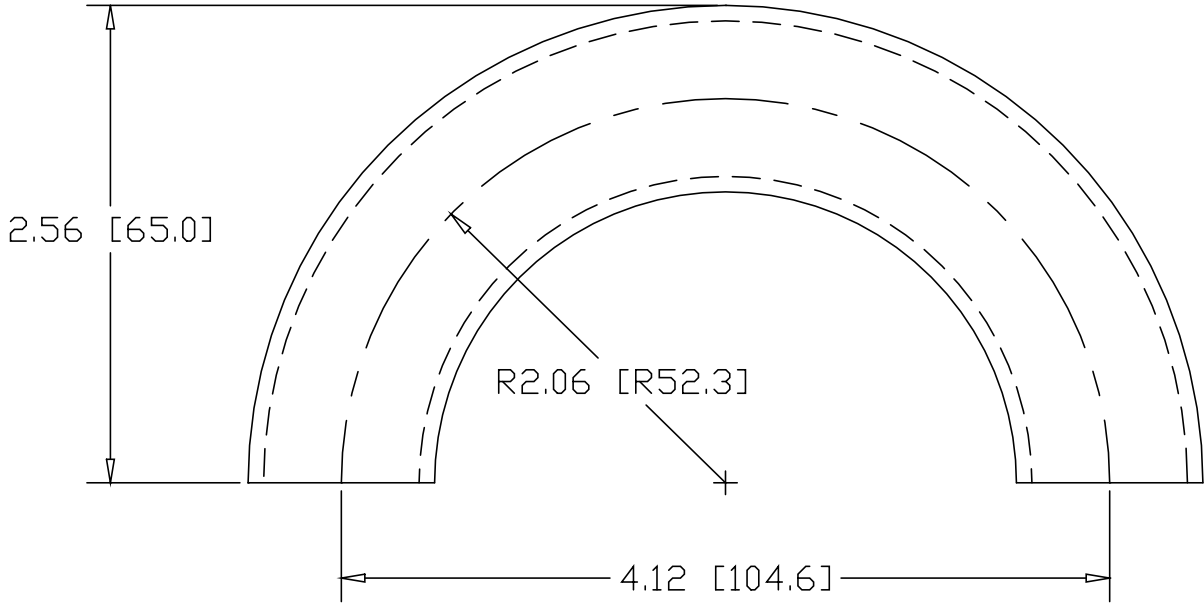

INCHES [MILLIMETERS]

ALTERNATE MATERIAL	PART NUMBER
1.00" OD X .125W (6061-T1) ALUMINUM TUBE	7828
1.00" OD X .083W (304) STAINLESS STEEL TUBE	7844

PART NAME		1.00" OD TUBE 180° ELL X 2.06" CLR			
MATERIAL		1.00" OD X .083W STEEL TUBE ASTM A513			
DATE	8/10/00	 R & B WAGNER, INC.			
DRAWN BY	RJF				
FINISH	MILL	SIZE	WEIGHT	PART NUMBER	REV
		A	.44 LBS	7812	