

REV
SH
DWG NO 3226D.5

REVISIONS			
REV	DESCRIPTION	DATE	APPROVED

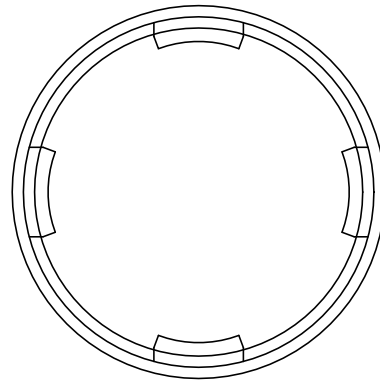
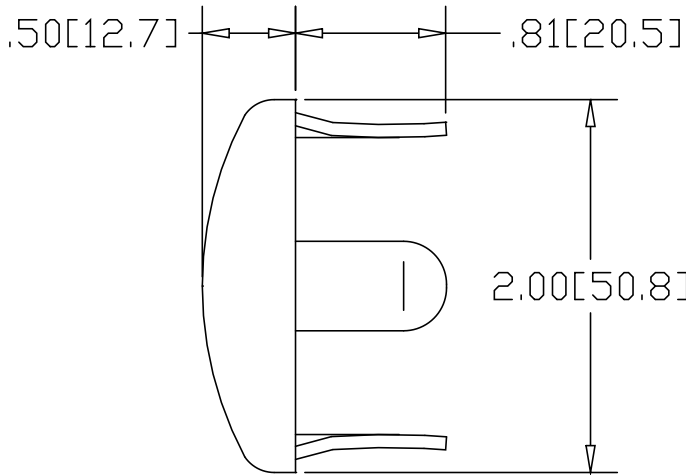
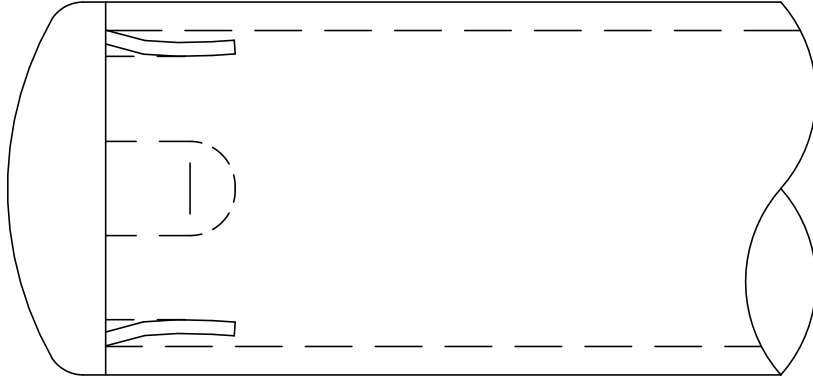
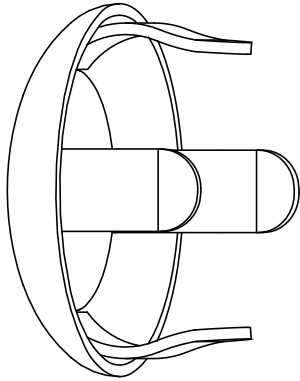

INCHES [MILLIMETERS]

ALTERNATE MATERIAL	PART NUMBER
.063 (3003) ALUMINUM ASTM B-209	3246D.5
16 GA. (304) STAINLESS STEEL ASTM A240	3266D.5

NOTE: ALUMINUM AND STAINLESS STEEL CAPS HAVE #4 SATIN FINISH.

PART NAME		2.00" OD X .065W TYPE "H" OVAL DRIVE-ON END CAP	
MATERIAL		16 GA. HRP&D STEEL ASTM A-569	
DATE	7/10/96	 THE WAGNER COMPANIES R & B WAGNER, INC. AND J. G. BRAUN CO.	
DRAWN BY	RJF		
FINISH	MILL SEE NOTE		
SIZE	A	WEIGHT	.14 LBS
		PART NUMBER	3226D.5
		REV	