

REV
SH
2528T
DWG NO

REVISIONS			
REV	DESCRIPTION	DATE	APPROVED

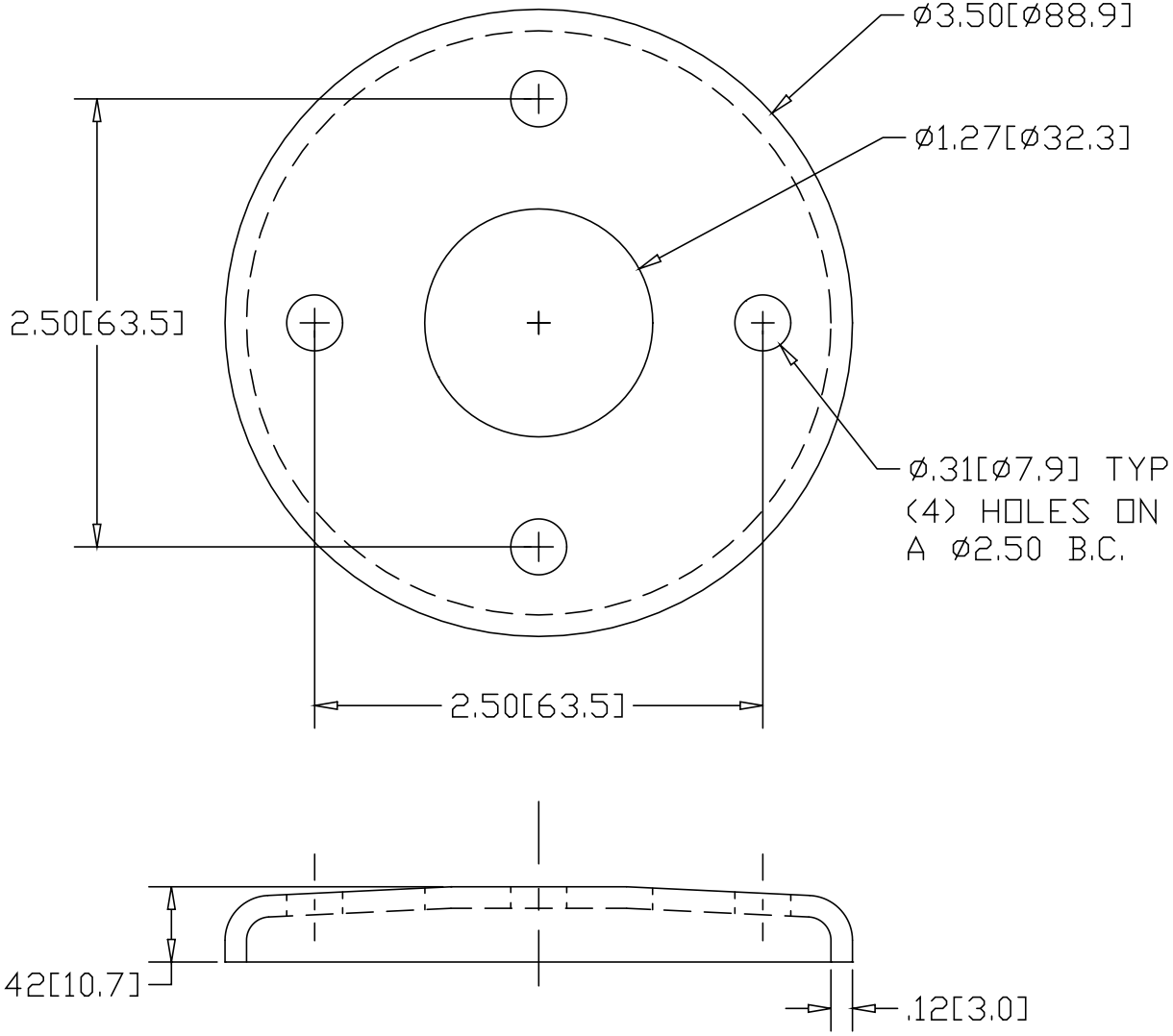

INCHES [MILLIMETERS]

*USE WITH ANCHOR PLATE
 #B1416 IN STEEL
 #PLB1416 ZINC PLATED STEEL
 #B1516 IN STAINLESS

ALTERNATE MATERIAL	PART NUMBER
.125 (3003) ALUMINUM ASTM B209	2568T
10 GA. (304) STAINLESS STEEL ASTM A240	2608T

PART NAME 1.25"OD TUBE HEAVY FLUSH BASE FLANGE W/(4) HOLES			
MATERIAL 10 GA. HRP&D STEEL ASTM A569			
DATE 3/31/99		R & B WAGNER, INC.	
DRAWN BY RJF		FINISH MILL	SIZE A
PART NUMBER 2528T		REV	