

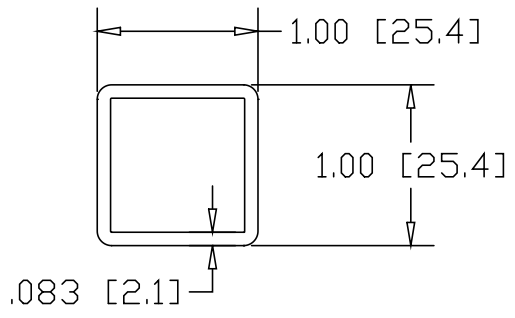

REV
SH
6312
DWG NO

REVISIONS			
REV	DESCRIPTION	DATE	APPROVED

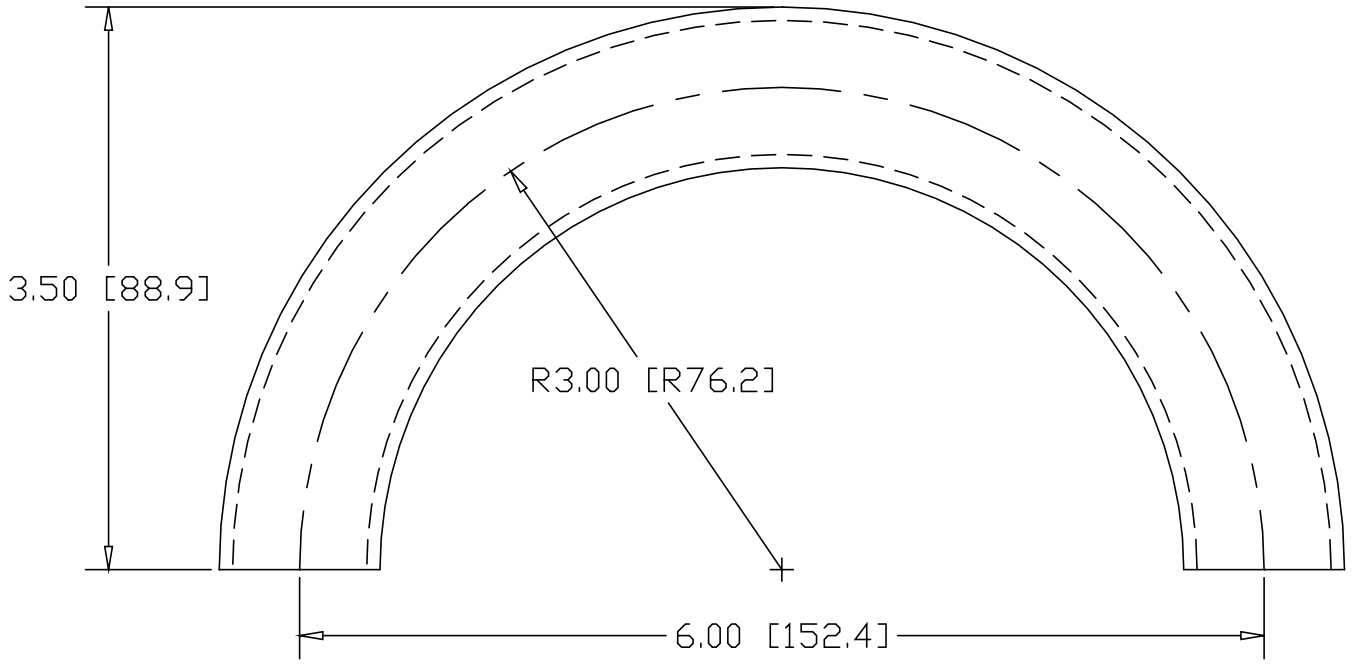

INCHES [MILLIMETERS]

PART NAME		1" SQUARE STEEL 180° X 3" CLR ELL					
MATERIAL		1.00" X .083W SQUARE STEEL TUBE					
DATE	10/3/00	 THE WAGNER COMPANIES R & B WAGNER, INC. AND J. G. BRAUN CO.					
DRAWN BY	RJF						
FINISH	MILL						
SIZE	A	WEIGHT	.82 LBS	PART NUMBER	6312	REV	