

REV
SH
7956
DWG NO

REVISIONS			
REV	DESCRIPTION	DATE	APPROVED

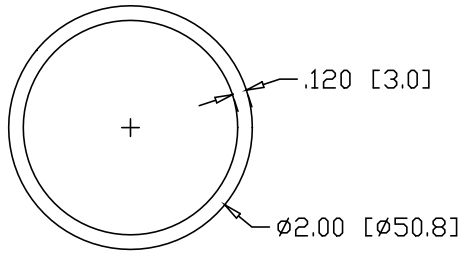
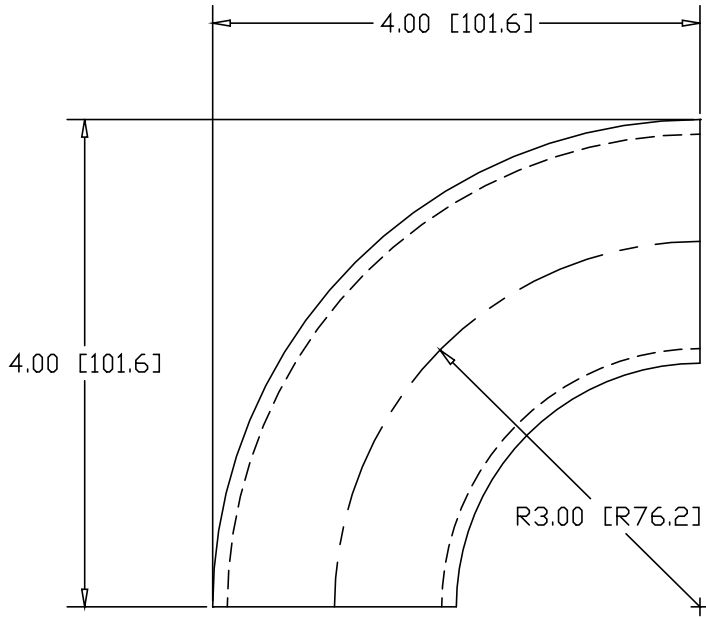

INCHES [MILLIMETERS]

ALTERNATE MATERIAL	PART NUMBER
2" Ø.D. X .125W (6061) ALUMINUM TUBE	7972
2" Ø.D. X .120W (304) STAINLESS STEEL TUBE	7988

PART NAME		2" Ø.D. TUBE 90° ELL X 3"CLR					
MATERIAL		2" Ø.D. X .120W STEEL TUBE					
DATE	8/24/00						
DRAWN BY	RJF						
FINISH	MILL						
SIZE	A	WEIGHT	.95 LBS	PART NUMBER	7956	REV	