

REV
SH
R180,316
DWG NO

REVISIONS			
REV	DESCRIPTION	DATE	APPROVED

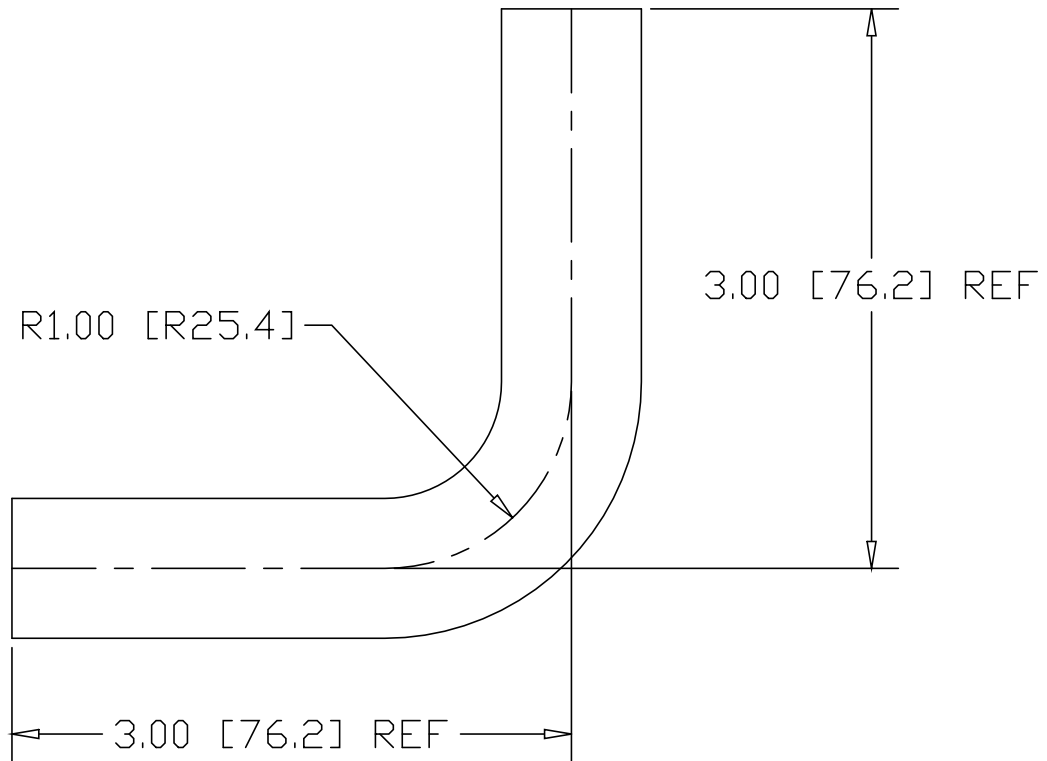
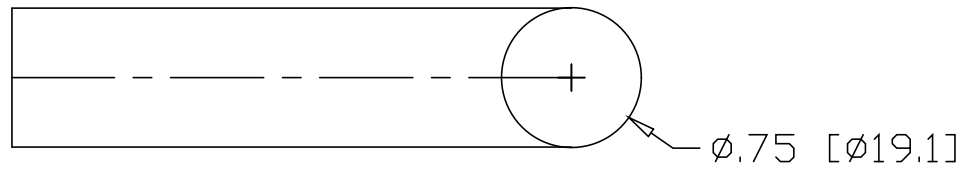

NOTE: ENDS UNTRIMMED

INCHES [MILLIMETERS]

ALTERNATE MATERIAL	PART NUMBER

PART NAME		3/4"Ø BAR BEND					
MATERIAL		3/4"Ø 316 STAINLESS STEEL BAR					
DATE	11/17/10	 THE WAGNER COMPANIES R & B WAGNER, INC. AND J. G. BRAUN CO.					
DRAWN BY	RDC						
FINISH	MILL						
SIZE	A	WEIGHT	.71 LBS	PART NUMBER	R180.316	REV	