

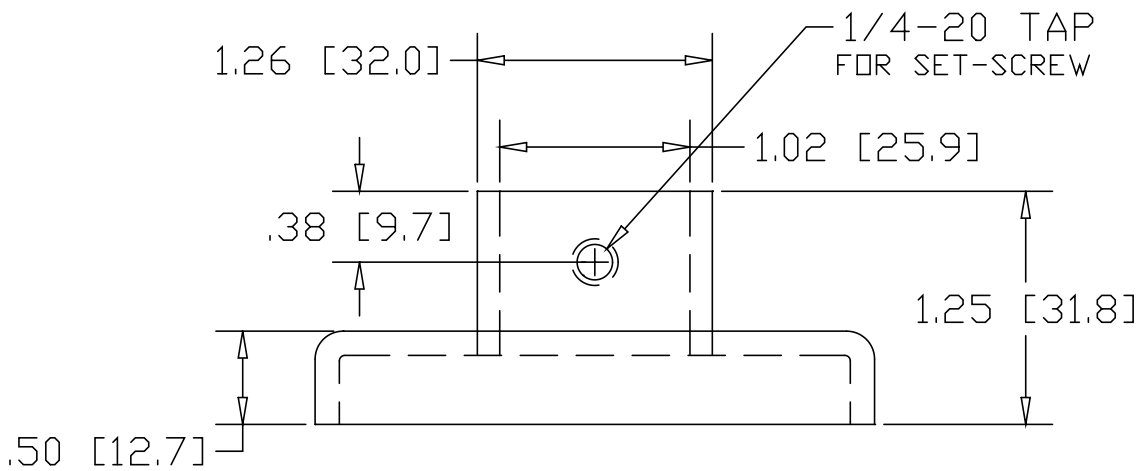

REV  
SH  
8904  
DWG NO

REVISIONS			
REV	DESCRIPTION	DATE	APPROVED

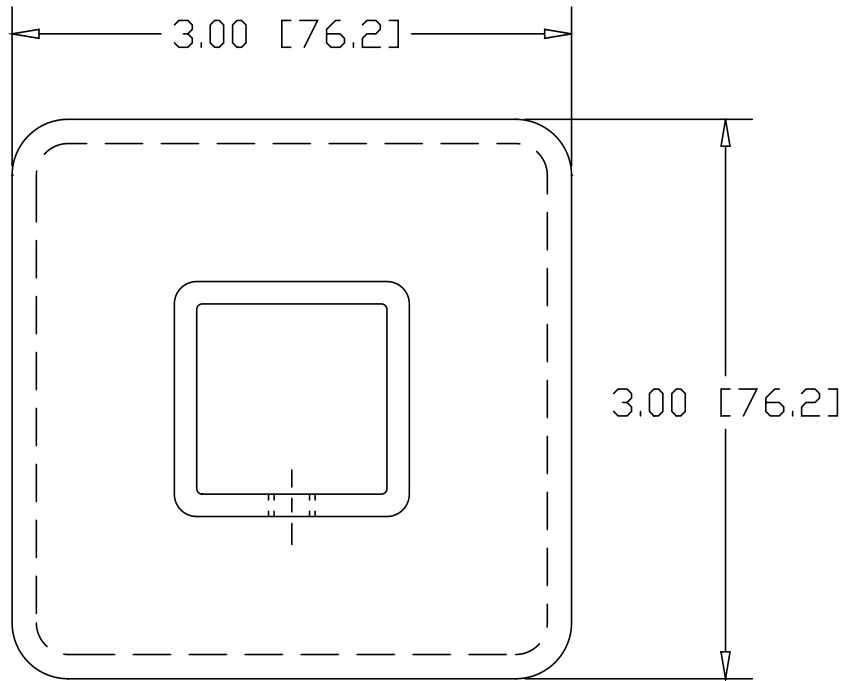

INCHES [MILLIMETERS]

ALTERNATE MATERIAL	PART NUMBER
.125 (3003) ALUMINUM ASTM B209	8928

PART NAME 1" SQ. TUBE SOCKET FLANGE W/ SET-SCREW				
MATERIAL 10 GA. HRP&D STEEL ASTM A569				
DATE 1/15/93	 <b>THE WAGNER COMPANIES</b> R & B WAGNER, INC. AND J. G. BRAUN CO.			
DRAWN BY RJF				
FINISH MILL		SIZE A	WEIGHT .51 LBS	PART NUMBER 8904
			REV	