

REV  
SH  
266  
DWG NO

REVISIONS			
REV	DESCRIPTION	DATE	APPROVED

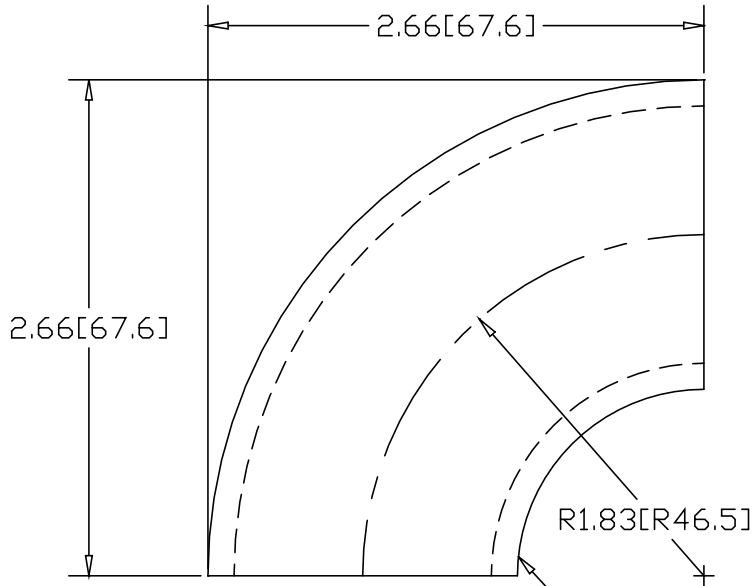

NOTE: UNWELDED SEAM  
ALONG INSIDE RADIUS

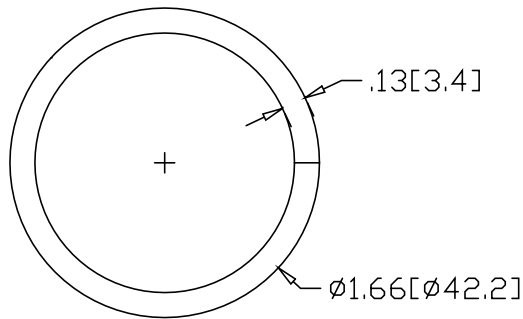

INCHES [MILLIMETERS]

ALTERNATE MATERIAL	PART NUMBER
.125 (3003) ALUMINUM ASTM B209	290
10 GA. (304) STAINLESS STEEL ASTM A240	315

PART NAME		1-1/4" PIPE 1" I.R. X 90° ELL		
MATERIAL		10 GA. HRP&D STEEL ASTM A569		
DATE	04/03/00	 <b>R &amp; B WAGNER, INC.</b>		
DRAWN BY	RJF			
FINISH	MILL			
SIZE	WEIGHT	PART NUMBER	REV	
A	.54 LBS	266		