

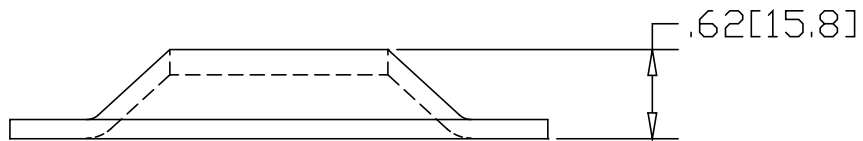

REV
SH
DWG NO 8047-NH

| REVISIONS | | | |
|-----------|-------------|------|----------|
| REV | DESCRIPTION | DATE | APPROVED |

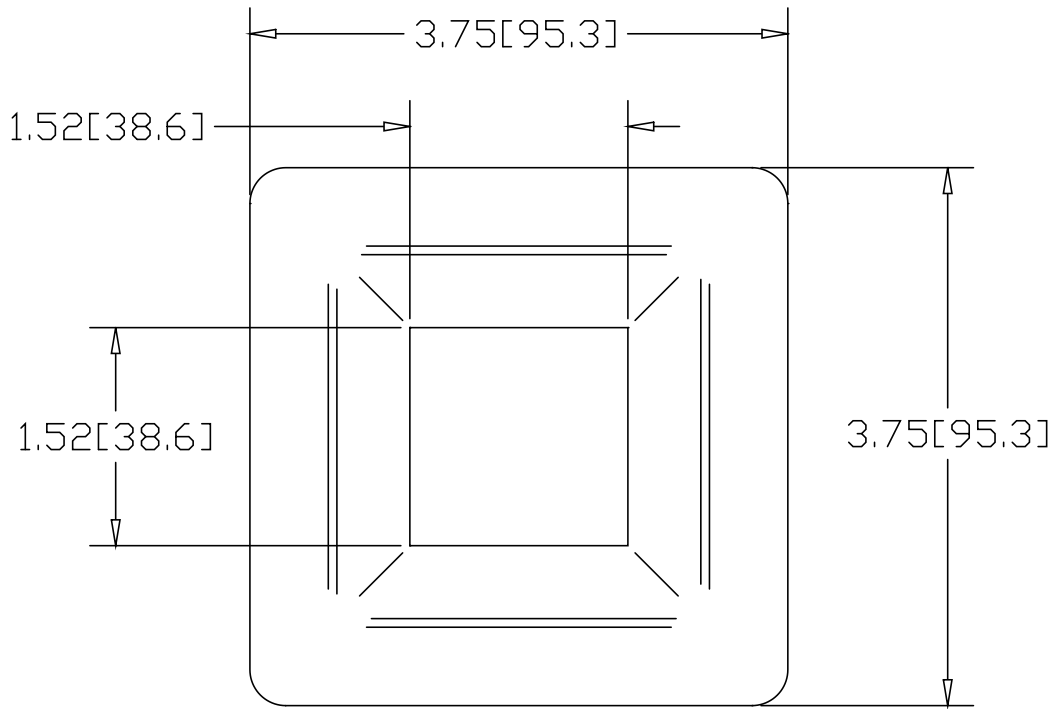

INCHES [MILLIMETERS]

| ALTERNATE MATERIAL | PART NUMBER |
|--------------------------------|-------------|
| .125 (3003) ALUMINUM ASTM B209 | 8048-NH |

| | | | | | |
|-----------|---------|---|---------|-------------|-----|
| PART NAME | | 1.50" SQUARE TUBE FLANGE | | | |
| MATERIAL | | 10 GA. HRP&D STEEL ASTM A569 | | | |
| DATE | 7/24/96 |  R & B WAGNER, INC. | | | |
| DRAWN BY | RJF | | | | |
| FINISH | MILL | SIZE | WEIGHT | PART NUMBER | REV |
| | | A | .46 LBS | 8047-NH | |