

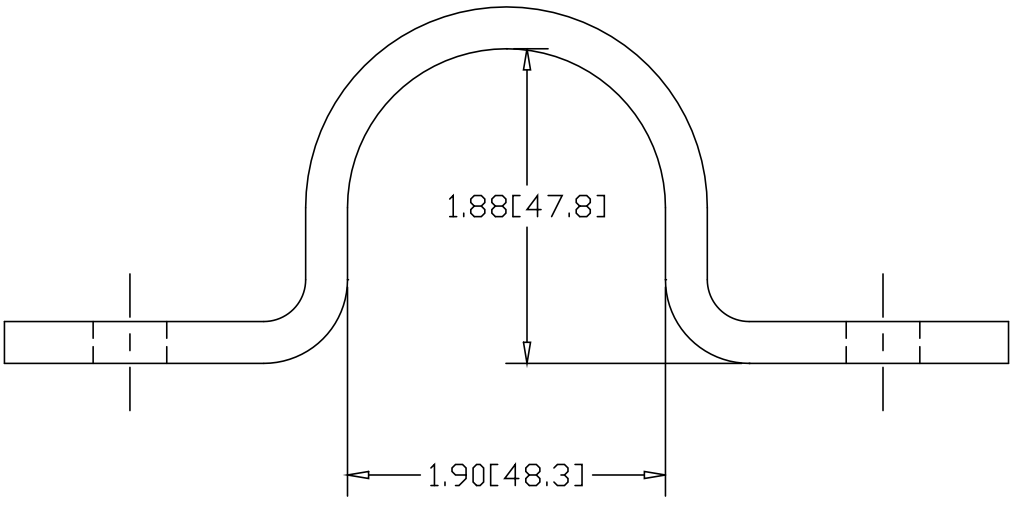

REV
SH
3752
DWG NO

REVISIONS			
REV	DESCRIPTION	DATE	APPROVED

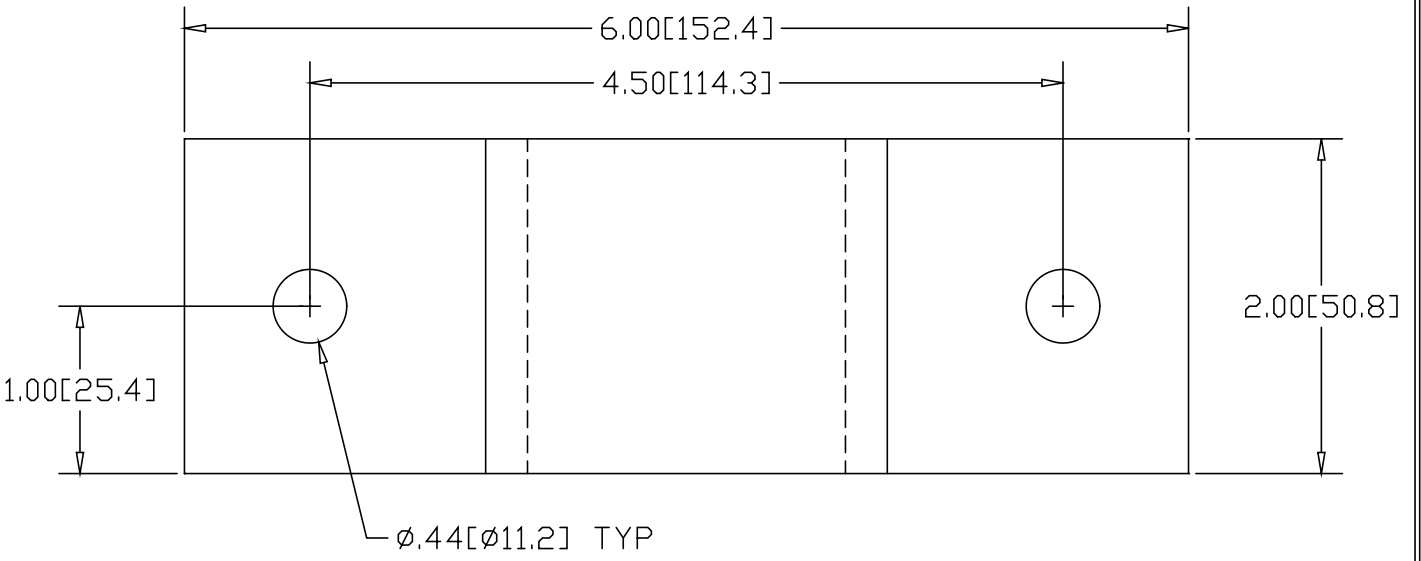

INCHES [MILLIMETERS]

ALTERNATE MATERIAL	PART NUMBER
.250 (3003) ALUMINUM ASTM B209	3758
7 GA. (304) STAINLESS STEEL ASTM A240	3764-SS

PART NAME 1-1/2" PIPE (1.90" OD) X 2" WIDE U-BRACKET W/(2) HOLES				
MATERIAL .250 HRP&D STEEL ASTM A569				
DATE 1/13/00	 THE WAGNER COMPANIES R & B WAGNER, INC. AND J. G. BRAUN CO.			
DRAWN BY RJF		SIZE A	WEIGHT 1.10 LBS	PART NUMBER 3752
FINISH MILL				REV