

2



1

PARTS LIST

ITEM	QTY	PART NUMBER	DESCRIPTION
1	1	GR2LL5075HCB8-10	Shoe Moulding, Aluminum, Level lock Plus, For .5 to .75 Glass, 2.75 Wide, 3.75 High, 10 Foot Lengths, Hole Counterbored, 8 in on Center, Mill Finish
2	1	LL1213	Level Lock Plus, Mechanism 10 Pack, for 1/2" Nominal Glass, .469-.550"
3	1	GR9LL1250	Shoe Isolator, Level Lock +, HDPE, 0.125 x 0.50 x 2.00, 10 pack

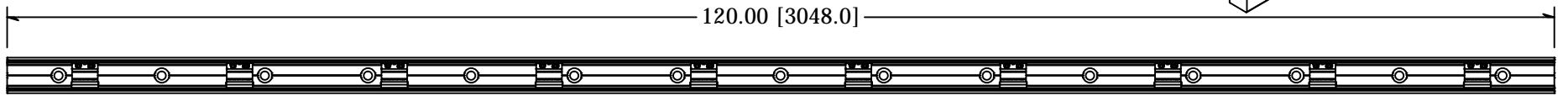
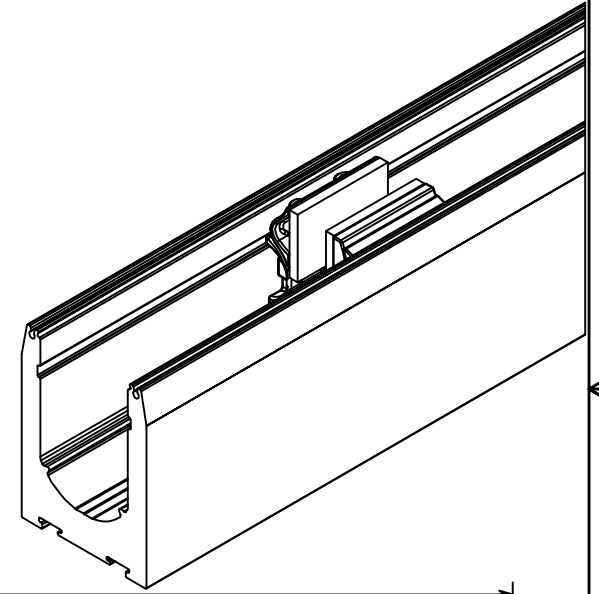
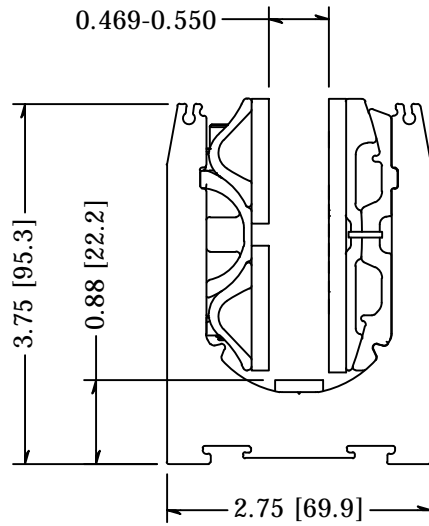

(15) Ø0.63 THRU
 Ø1.13

TOLERANCE X.XX +/- 0.01 X.XXX +/- 0.005 Angle +/- 0.5 Unless Otherwise Specified	CUT LENGTH:	FINISH:	DESCRIPTION: Level Lock Plus, Sales kit, for 1/2"-9/16", 13mm glass, 10ft shoe HCB 8" O.C., W/ Mechanisms	
	DEVELOPED LENGTH:	WEIGHT:	MATERIAL:	MATERIAL DESC:
	10FT	N/A	DATE: 4/7/2021	REV: 1
	TOOL NUMBER:		DRAWN BY: A. Seeboth	PART NUMBER: LL1213.8KIT10
			WAGNER ™ 10600 W Brown Deer Rd Milwaukee, WI 53224 COLLABORATIVE METALWORKS http://www.wagnercompanies.com/	

2



1