

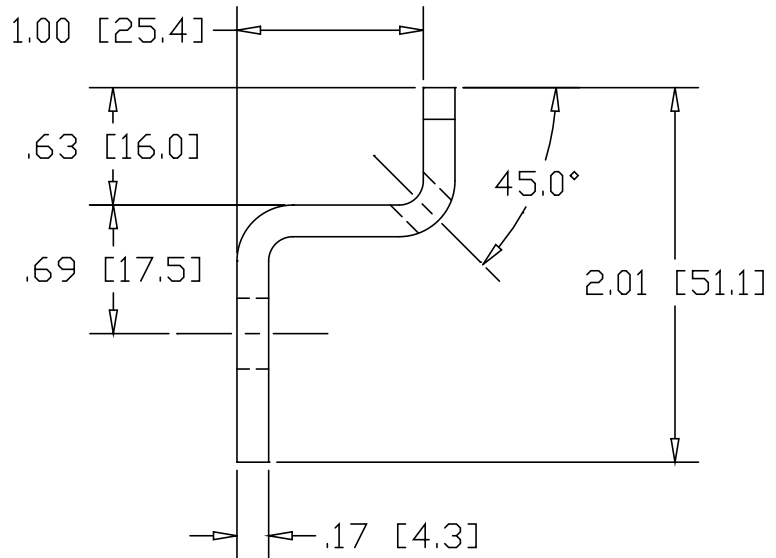

REV
SH
11
DWG NO

REVISIONS			
REV	DESCRIPTION	DATE	APPROVED

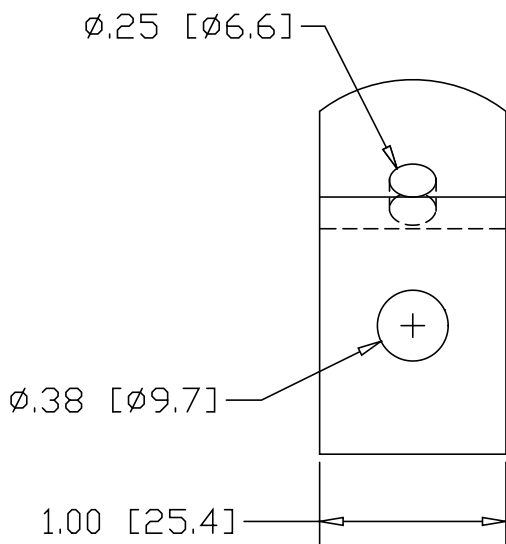
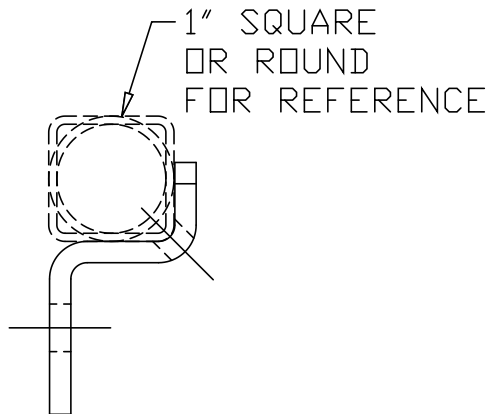

INCHES [MILLIMETERS]

ALTERNATE MATERIAL	PART NUMBER
8 GA. HRP&D STEEL ASTM A569 ZINC PLATED	11P
.188 X 1.00 6063-T52 ALUMINUM BAR	12

PART NAME				FRAME MOUNT BRACKET 1.00" OFFSET WITH CORNER HOLE			
MATERIAL				8 GA. HRP&D STEEL ASTM A569			
DATE	8/15/03	 THE WAGNER COMPANIES R & B WAGNER, INC. AND J. G. BRAUN CO.		SIZE		WEIGHT	
DRAWN BY	RJF			A		.115 LBS	
FINISH	MILL			PART NUMBER		11	
				REV			