

REV
SH
410
DWG NO

REVISIONS			
REV	DESCRIPTION	DATE	APPROVED

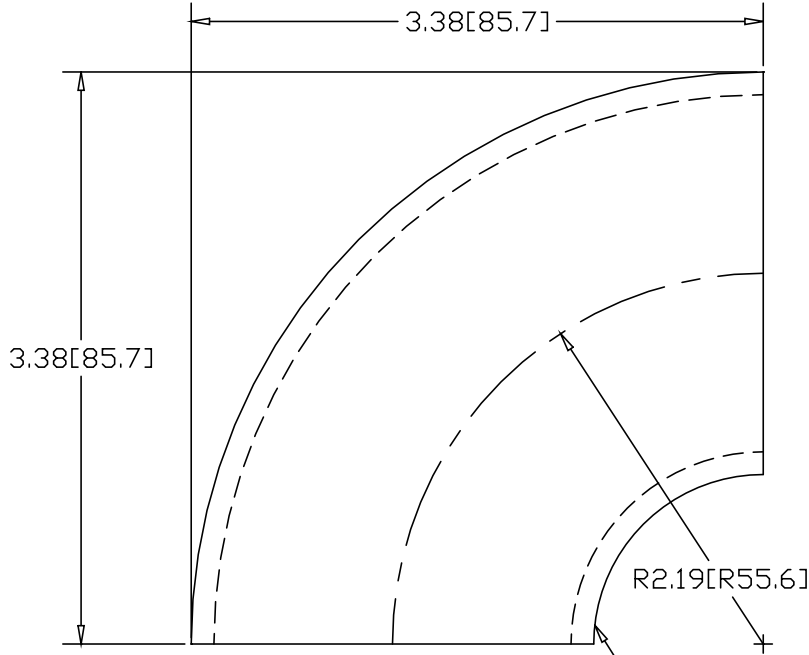

NOTE: UNWELDED SEAM ALONG INSIDE RADIUS

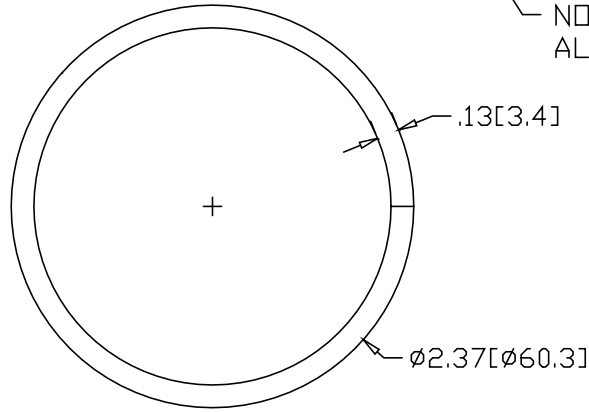

INCHES [MILLIMETERS]

ALTERNATE MATERIAL	PART NUMBER
.125 (3003) ALUMINUM ASTM B209	434
10 GA. (304) STAINLESS STEEL ASTM A240	459-1

PART NAME		2" PIPE SIZE 1" I.R. X 90° ELL					
MATERIAL		10 GA. HRP&D STEEL ASTM A569					
DATE	8/17/95						
DRAWN BY	RJF						
FINISH	MILL						
SIZE	A	WEIGHT	1.13 LBS	PART NUMBER	410	REV	