

REVISIONS			
REV	DESCRIPTION	DATE	APPROVED

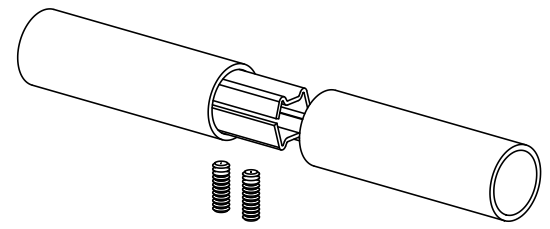

2.50" OD X .120W TUBE

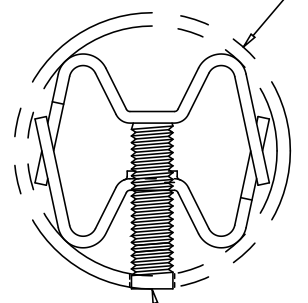

3/8-16
SOCKET HEAD
SET-SCREW
(2) PLACES

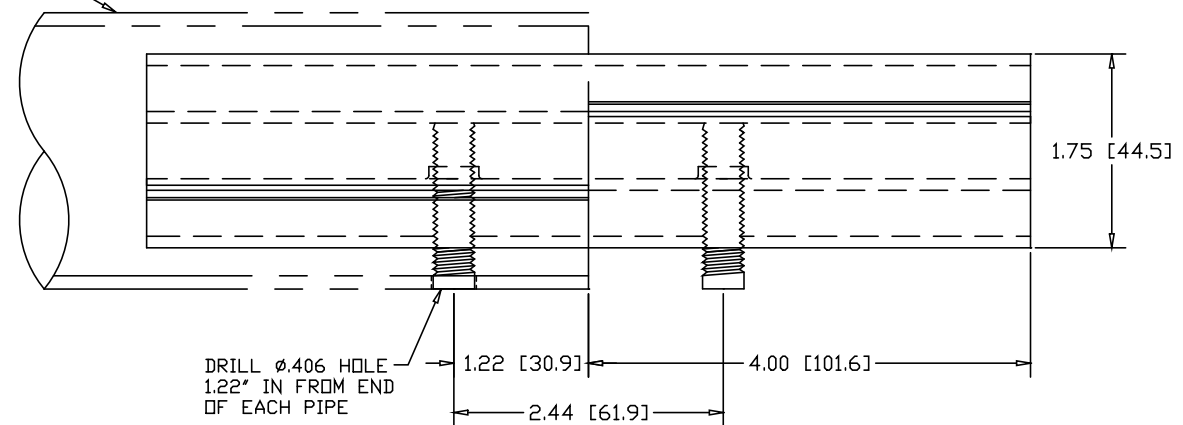
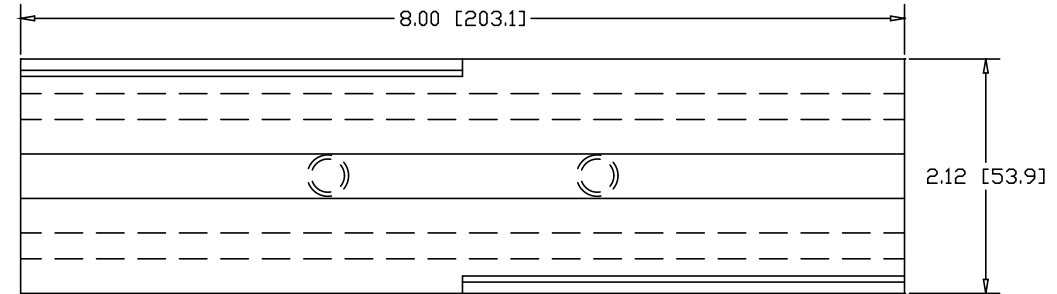

DRILL ϕ .406 HOLE
1.22" IN FROM END
OF EACH PIPE

INCHES [MILLIMETERS]

ALTERNATE MATERIAL	PART NO.
12 GA. STEEL HOT DIP GALVANIZED	G3391-8
12 GA. STEEL ZINC PLATED	PL3391-8
.090 (3003) ALUMINUM ASTM B209	3392-8
.090 (304) STAINLESS STEEL ASTM A240	3393-8

PART NAME		2.50" OD X .120W TUBE DOUBLE-LOCK SPLICE-LOCK 8" LONG					
MATERIAL		12 GA. HRP&D STEEL ASTM A569					
DATE	9/21/01	 R & B WAGNER, INC.					
DRAWN BY	JAH						
FINISH	MILL						
SIZE	A	WEIGHT	1.80 LBS	PART NUMBER	3391-8	REV	