

REVISIONS			
REV	DESCRIPTION	DATE	APPROVED

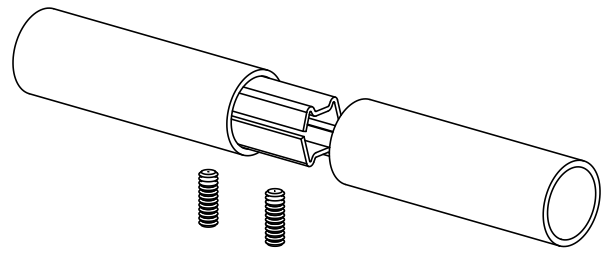

2.00" OD X .065W TUBE

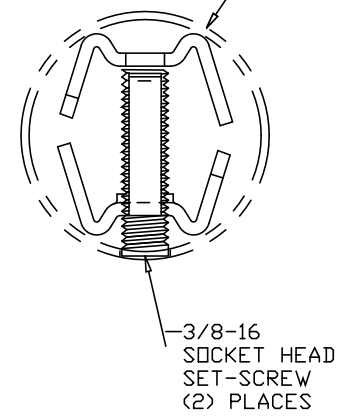

3/8-16
SOCKET HEAD
SET-SCREW
(2) PLACES

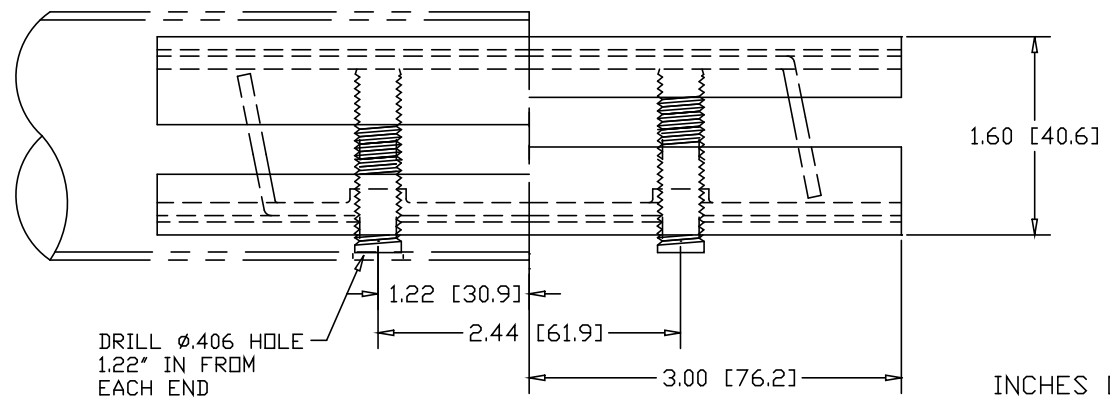
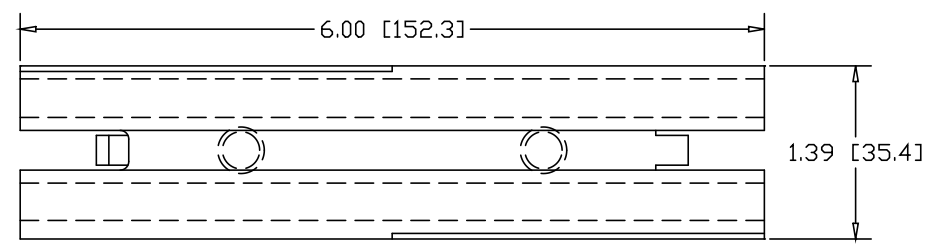

DRILL ϕ .406 HOLE
1.22" IN FROM
EACH END

INCHES [MILLIMETERS]

ALTERNATE MATERIAL	PART NO.
12 GA. STEEL HOT DIP GALVANIZED	G3378-6
12 GA. STEEL ZINC PLATED	PL3378-6
.125 (3003) ALUMINUM ASTM B209	3379-6
.090 (304) STAINLESS STEEL ASTM A240	3380-6

PART NAME		2.00" OD X .065W DOUBLE-LOCK SPLICE-LOCK 6" LONG		
MATERIAL		12 GA. HRP&D STEEL ASTM A569		
DATE	3/22/93		THE WAGNER COMPANIES R & B WAGNER, INC. AND J. G. BRAUN CO.	
DRAWN BY	RJF			
FINISH	MILL	SIZE	WEIGHT	PART NUMBER
		A	.88 LBS	3378-6
				REV