

REV
SH
DWG NO 8727

REVISIONS			
REV	DESCRIPTION	DATE	APPROVED

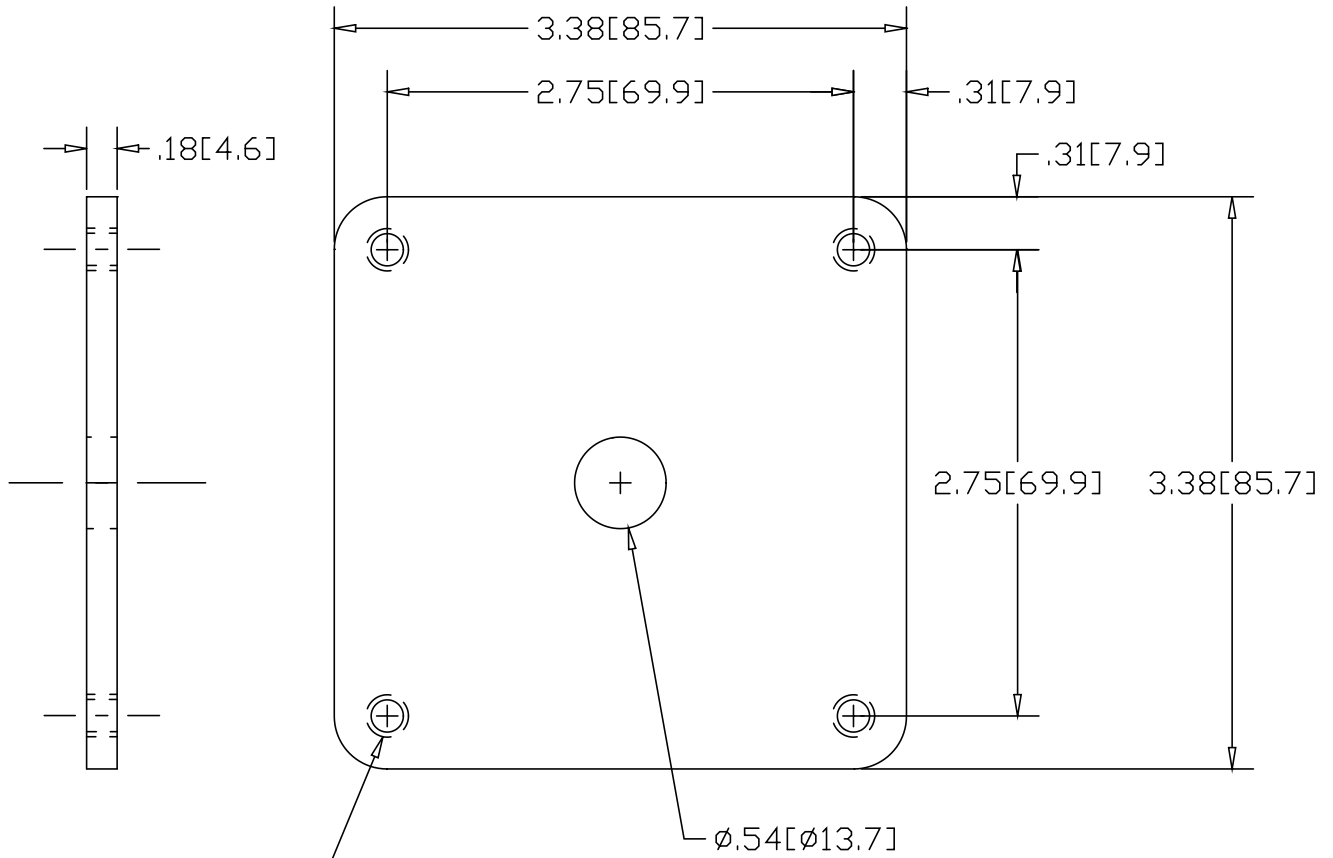

1/4-20 TAP THRU
(4) PLACES

Ø.54 [Ø13.7]

*INCLUDES (4) 1/4-20 X 3/8" FLAT HEAD SCREWS

INCHES [MILLIMETERS]

ALTERNATE MATERIAL	PART NUMBER
.190 (3003) ALUMINUM ASTM B209	8797
7 GA. (304) STAINLESS STEEL ASTM A240	8867

PART NAME		SQUARE ANCHOR PLATE		
MATERIAL		7 GA. HRP&O STEEL ASTM A569		
DATE	7/10/95	 R & B WAGNER, INC.		
DRAWN BY	RJF			
FINISH	MILL	SIZE	WEIGHT	PART NUMBER
		A	.54 LBS	8727
				REV