

REV

SH

DWG NO H1248CL

REV

REVISIONS

REV	DESCRIPTION	DATE	APPROVED
-----	-------------	------	----------

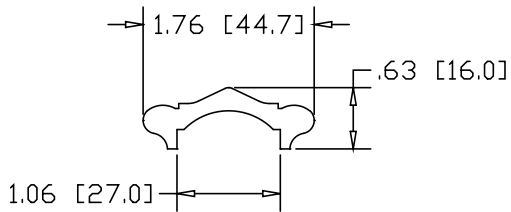
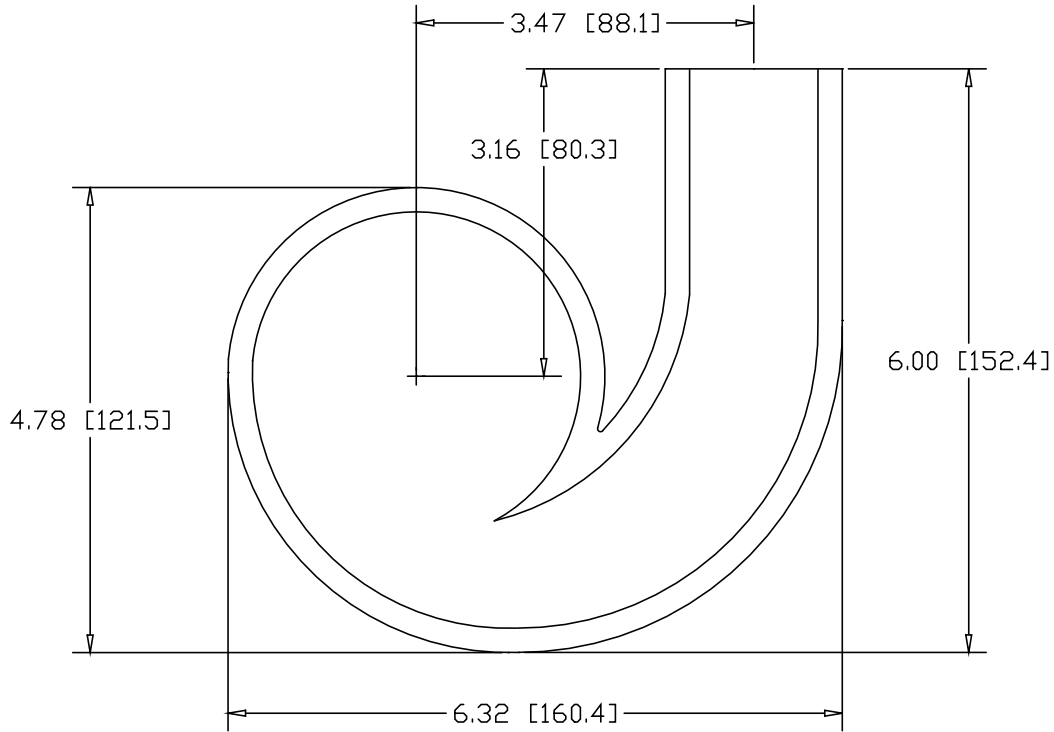

INCHES [MILLIMETERS]

PART NAME		JUNIOR LATERAL SCROLL, LEFT HAND				
MATERIAL		MALLEABLE IRON ASTM A47				
DATE	8/22/03		THE WAGNER COMPANIES R & B WAGNER, INC. AND J. G. BRAUN CO.			
DRAWN BY	RJF					
FINISH	AS-CAST					
SIZE	A	WEIGHT	1.58 LBS	PART NUMBER	H1248CL	REV