

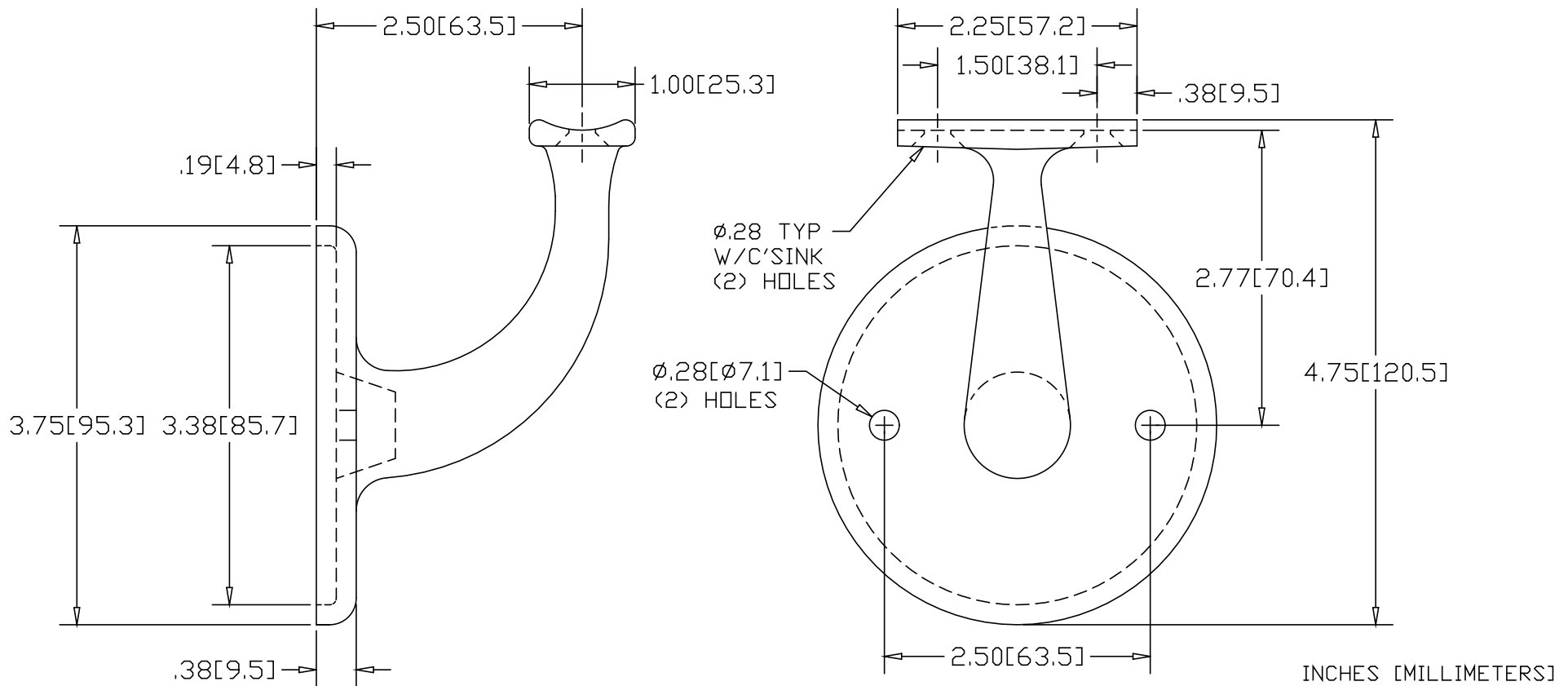

REVISIONS			
REV	DESCRIPTION	DATE	APPROVED



INCHES [MILLIMETERS]

ALTERNATE MATERIAL	PART NO.
ALMAG 535.2 ALUMINUM ASTM B26	1717-2 ANODIZED 1717-2AN
(304) STAINLESS STEEL ASTM A743	1731-2
(424) BRONZE ASTM C86300	1742-2
(405.1) BRASS ASTM C85800	1703-2BRS

PART NAME		2-1/2" CAST HANDRAIL BRACKET W/ (2) MOUNTING HOLES		
MATERIAL		MALLEABLE IRON CASTING ASTM A47-74		
DATE	10/31/95	 <b>THE WAGNER COMPANIES</b> R & B WAGNER, INC. AND J. G. BRAUN CO.	PART NUMBER	1703-2
DRAWN BY	RJF			
FINISH	SHOT BLASTED	SIZE	WEIGHT	REV
*NOTE: BRACKETS IN ALUMINUM, STAINLESS, BRASS AND BRONZE HAVE 180 GRIT #4 SATIN FINISH.		A	1.29 LBS	
*SEE NOTE				