

REVISION HISTORY

| REV | DESCRIPTION | DATE | APPROVED |
|-----|--------------------|----------|----------|
| 3 | REPLACED MODEL | 04/06/16 | RJF |
| 4 | PULLS FROM EXP1771 | 9/20/16 | KGB |

NOTE 1: CLEARANCE PER R&B
WAGNER QWI.QAL.0032
NOTE 2: NO SHARP EDGES

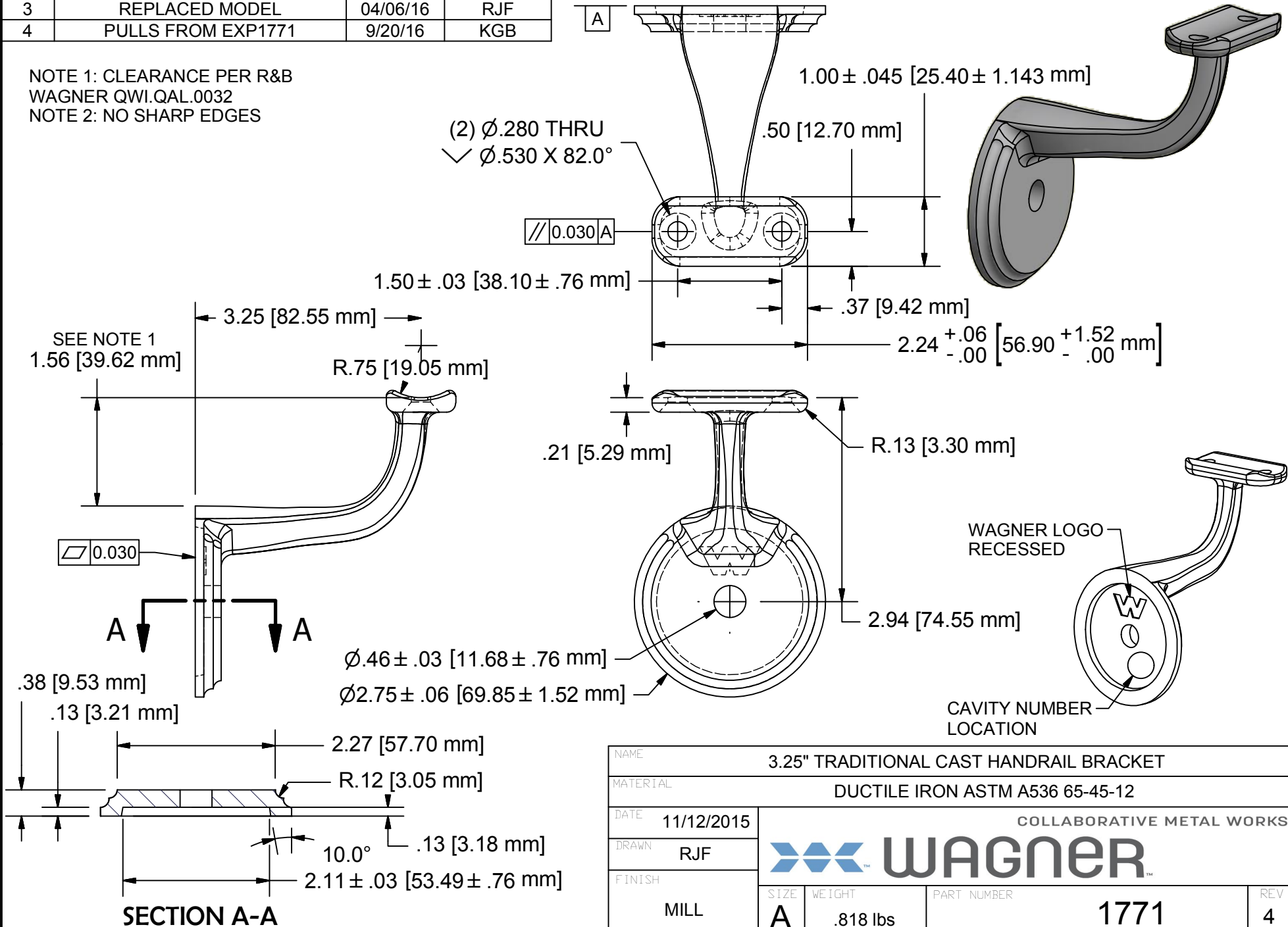

| | | | | | | | |
|----------|------------|---|----------|-------------|------|-----|---|
| NAME | | 3.25" TRADITIONAL CAST HANDRAIL BRACKET | | | | | |
| MATERIAL | | DUCTILE IRON ASTM A536 65-45-12 | | | | | |
| DATE | 11/12/2015 | COLLABORATIVE METAL WORKS | | | | | |
| DRAWN | RJF | | | | | | |
| FINISH | MILL | | | | | | |
| SIZE | A | WEIGHT | .818 lbs | PART NUMBER | 1771 | REV | 4 |