

REV
SH
DWG NO 6901

REVISIONS			
REV	DESCRIPTION	DATE	APPROVED

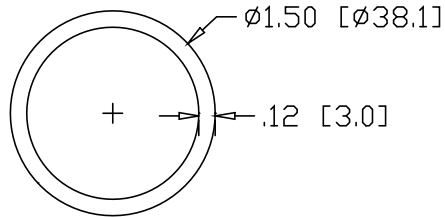
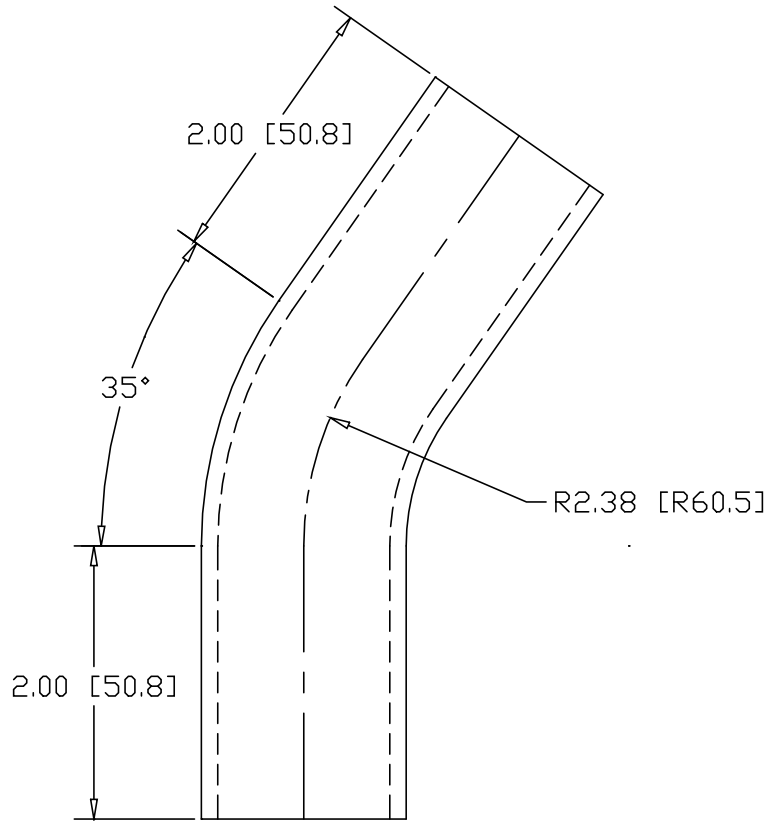

INCHES [MILLIMETERS]

ALTERNATE MATERIAL	PART NUMBER
1.50" O.D. X .125W (6061-T1) ALUMINUM TUBE	6917
1.50" O.D. X .120W (304) STAINLESS STEEL TUBE	6933

PART NAME 1.50" O.D. TUBE 35° ELL X 2.38" CLR W/(2) 2" TANGENTS				
MATERIAL 1.50" O.D. X .120W STEEL TUBE				
DATE 9/12/00				
DRAWN BY RJF				
FINISH MILL	SIZE A	WEIGHT .81 LBS	PART NUMBER 6901	REV