

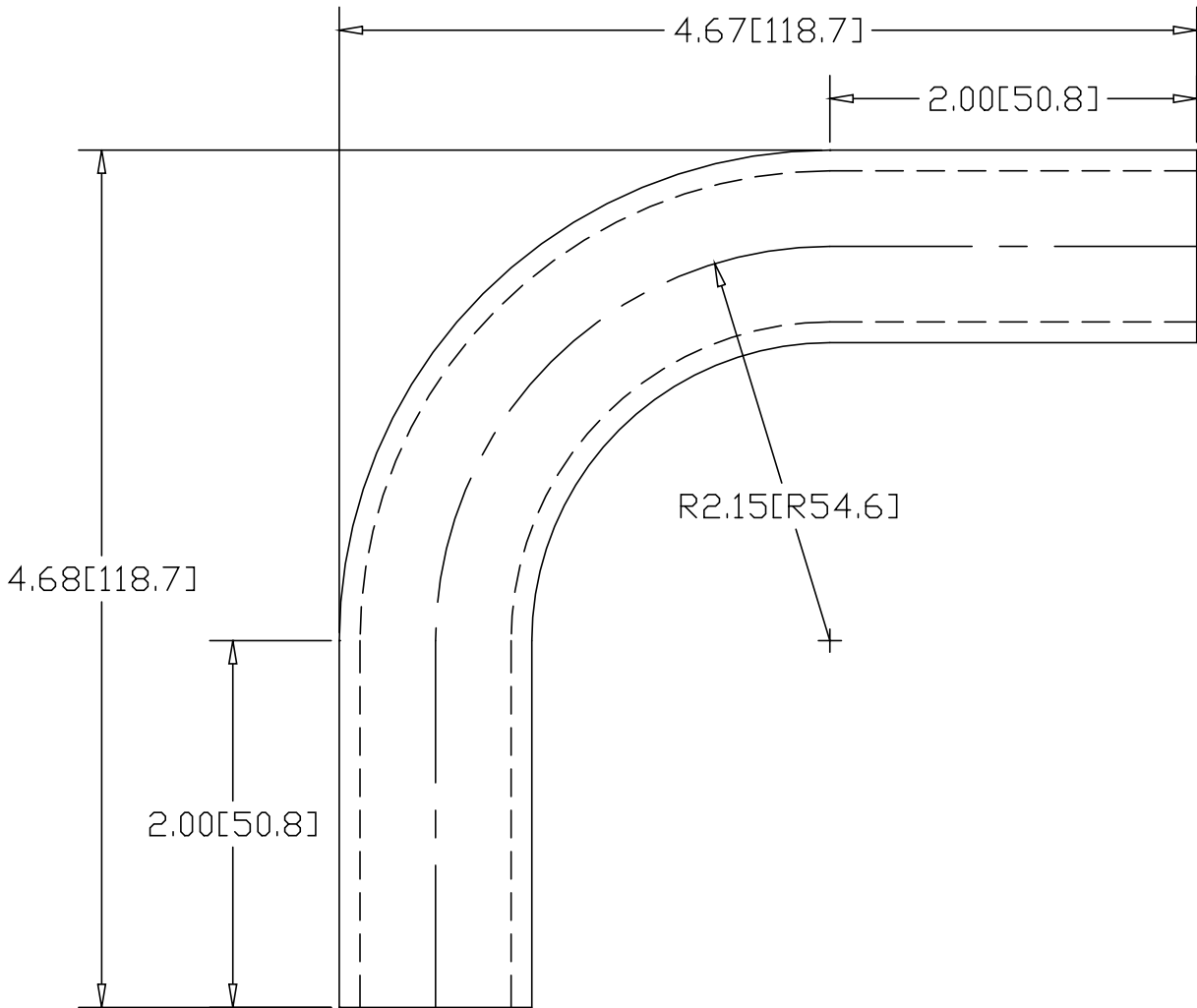

REV
SH
155-8
DWG NO

REVISIONS			
REV	DESCRIPTION	DATE	APPROVED



INCHES [MILLIMETERS]

ALTERNATE MATERIAL	PART NUMBER
3/4" SCH 40 (6063) ALUMINUM PIPE	165-2
3/4" SCH 40 (304) STAINLESS STEEL PIPE	175-2

PART NAME 3/4" PIPE SIZE 90° ELL X 1-5/8" I.R. W/(2) 2" TANGENTS			
MATERIAL 3/4" SCH 40 A53 STEEL PIPE			
DATE 8/18/95		R & B WAGNER, INC.	
DRAWN BY RJF		SIZE A	WEIGHT .70 LBS
FINISH MILL			REV