

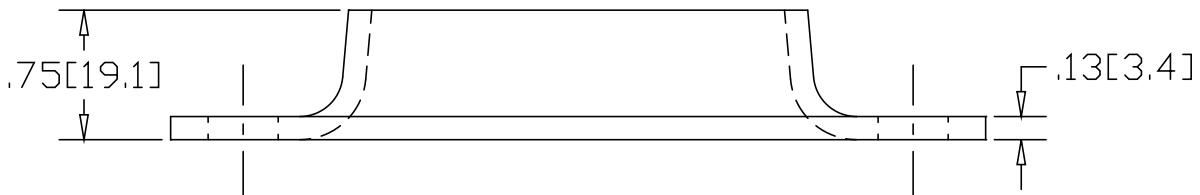

REV
SH
643
DWG NO

REVISIONS			
REV	DESCRIPTION	DATE	APPROVED

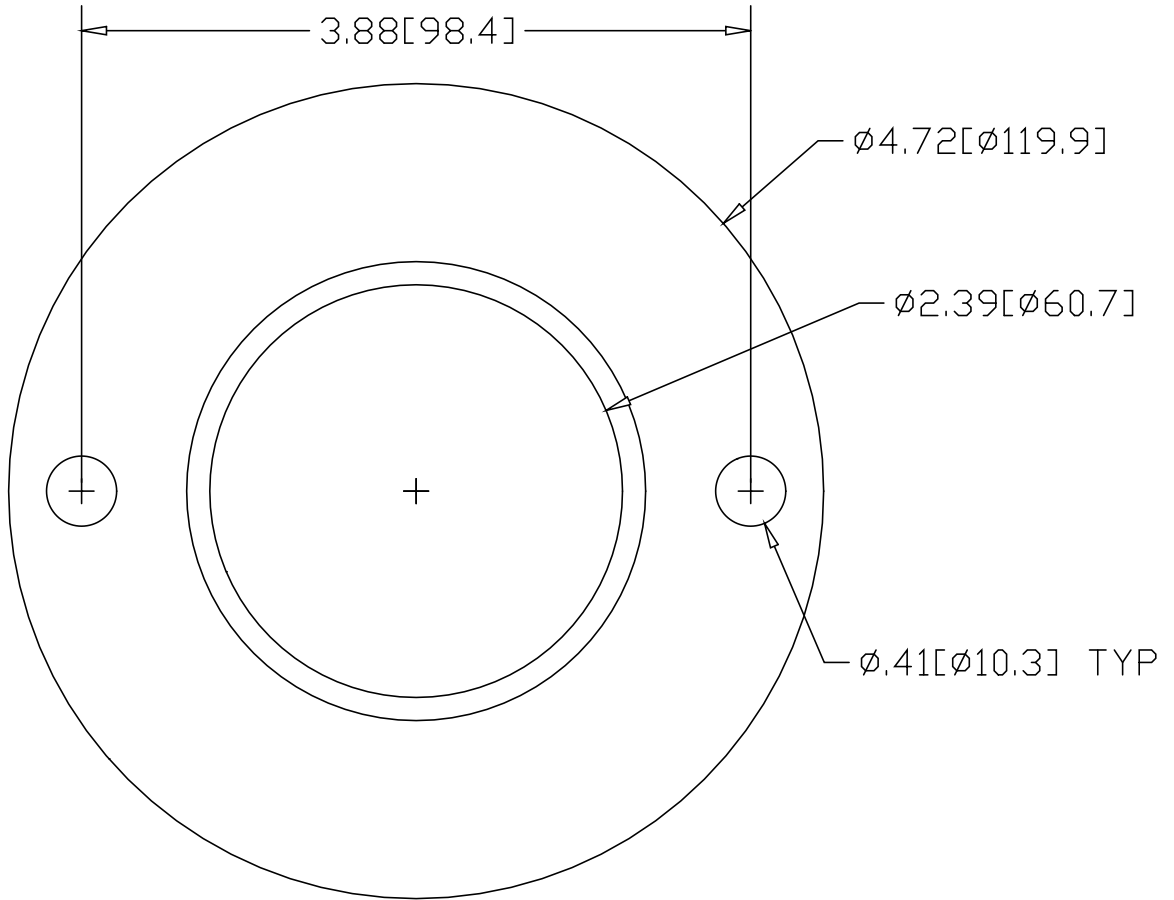

INCHES [MILLIMETERS]

ALTERNATE MATERIAL	PART NUMBER
.125 (3003) ALUMINUM ASTM B209	683
10 GA. (304) STAINLESS STEEL ASTM A240	726

PART NAME				2" FLAT BASE PIPE FLANGE WITH (2) HOLES			
MATERIAL				10 GA. HRP&D STEEL ASTM A-569			
DATE		1/8/99				R & B WAGNER, INC.	
DRAWN BY		RJF					
FINISH		MILL		SIZE	WEIGHT	PART NUMBER	REV
				A	.68 LBS	643	