

REVISIONS			
REV	DESCRIPTION	DATE	APPROVED

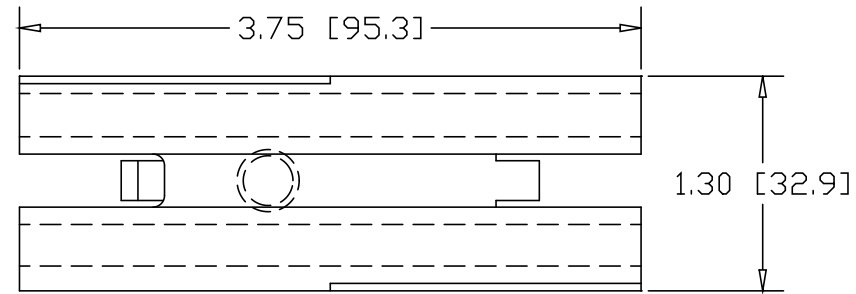

1-1/4" SCHEDULE 40 PIPE  
(1.66 O.D. X .140 WALL)

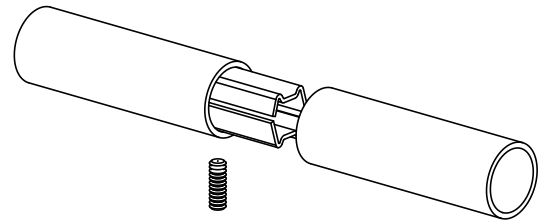
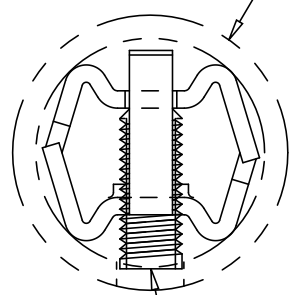

3/8-16 SOCKET HEAD  
SET-SCREW X 1" LG

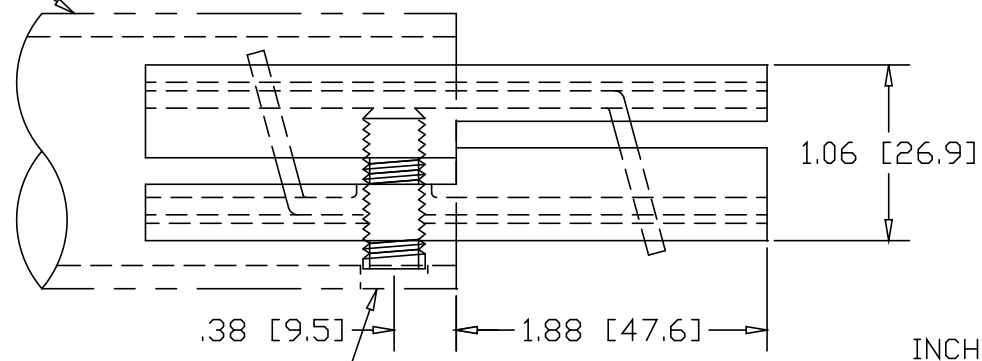

DRILL Ø.406 HOLE  
.38" IN FROM END

INCHES [MILLIMETERS]

ALTERNATE MATERIAL	PART NO.
12 GA. STEEL HOT DIP GALVANIZED	G3314
12 GA. STEEL ZINC PLATED	PL3314
.090 (3003) ALUMINUM ASTM B209	3315
.090 (304) STAINLESS STEEL ASTM A240	3317

PART NAME		1-1/4" SCH40 PIPE SINGLE-LOCK SPLICE-LOCK		
MATERIAL		12 GA. HRP&D STEEL ASTM A569		
DATE	3/22/93		<b>THE WAGNER COMPANIES</b> R & B WAGNER, INC. AND J. G. BRAUN CO.	
DRAWN BY	RJF			
FINISH	MILL	SIZE	WEIGHT	PART NUMBER
		A	.43 LBS	3314
				REV