

REV
SH
1435T
DWG NO

REVISIONS			
REV	DESCRIPTION	DATE	APPROVED

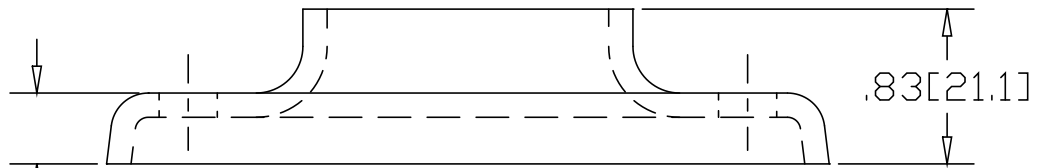
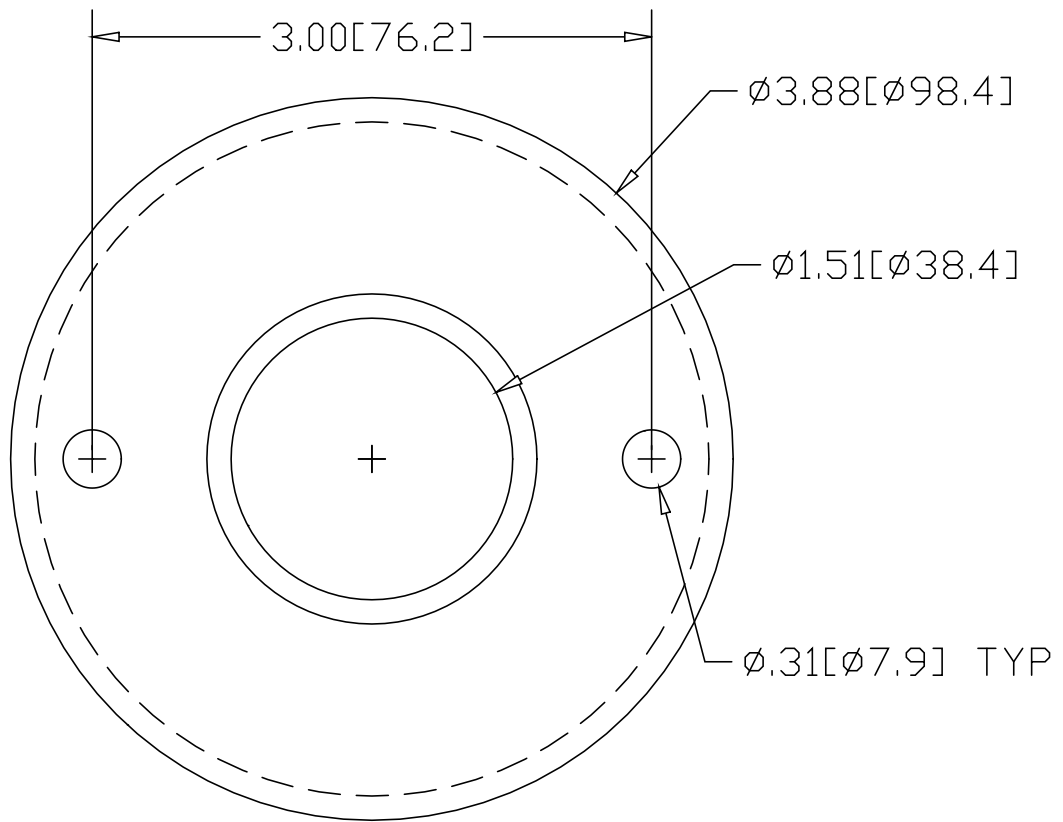

INCHES [MILLIMETERS]

*USE WITH ANCHOR PLATE

#B1432 IN STEEL

#PLB1432 ZINC PLATED STEEL

#B1532 IN STAINLESS

ALTERNATE MATERIAL	PART NUMBER
.125 (3003) ALUMINUM ASTM B209	1475T
10 GA. (304) STAINLESS STEEL ASTM A240	1535T

PART NAME 1.50" OD TUBE HEAVY BASE FLANGE W/(2) HOLES			
MATERIAL 10 GA. HRP&D STEEL ASTM A569			
DATE 9/13/94	 R & B WAGNER, INC.		
DRAWN BY RJF			
FINISH MILL	SIZE A	WEIGHT .50 LBS	PART NUMBER 1435T
			REV