

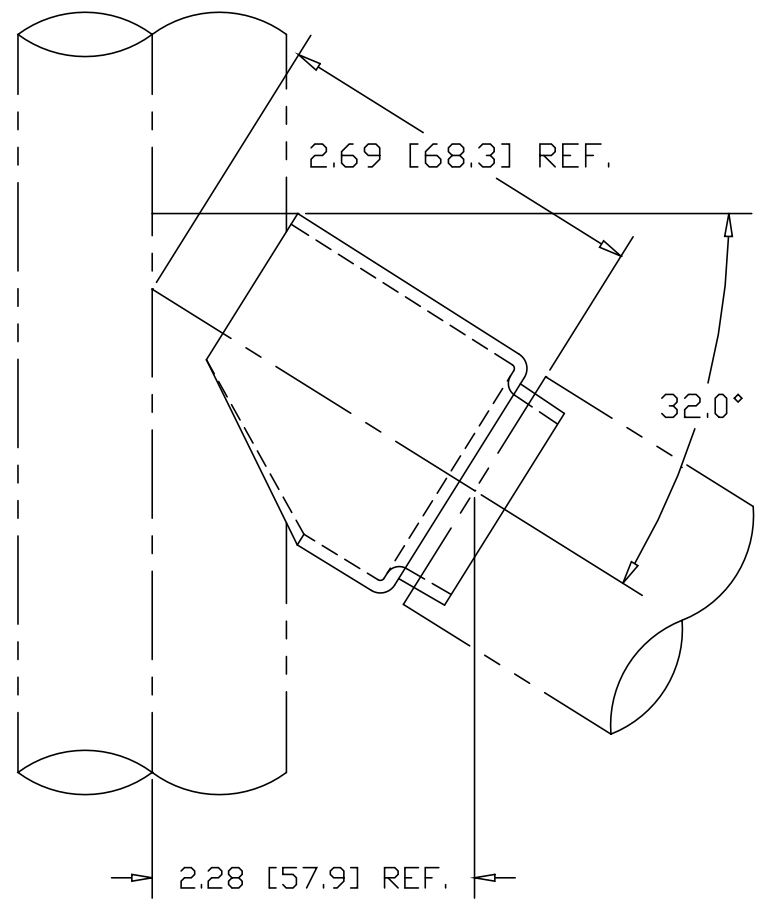

REVISIONS			
REV	DESCRIPTION	DATE	APPROVED

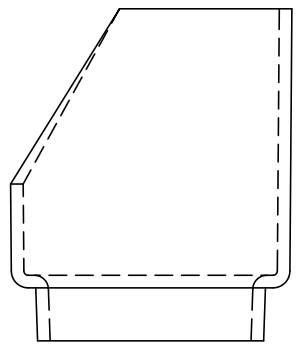
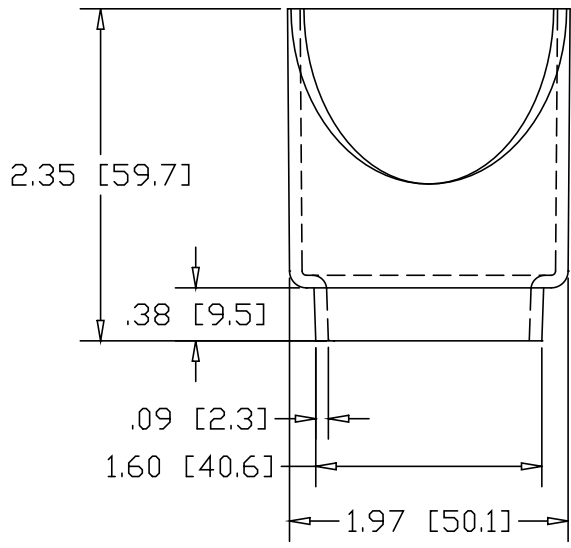
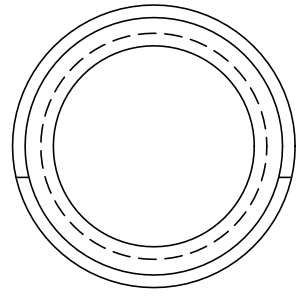
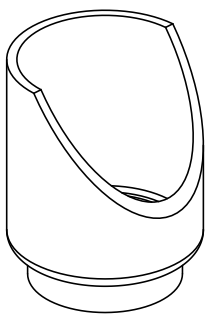

INCHES [MILLIMETERS]

PART NAME 1-1/2" SCH 40 PIPE 32° TYPE "F" COPED WELDING CONNECTOR			
MATERIAL 13 GA. (.089) HRP&D STEEL ASTM A569			
DATE 10/31/01		THE WAGNER COMPANIES R & B WAGNER, INC. AND J. G. BRAUN CO.	
DRAWN BY JAH			
FINISH MILL	SIZE A	WEIGHT .26 LBS.	PART NUMBER 1883
			REV