

REV A  
C  
SH  
SR1M-SM  
DWG NO

REVISIONS			
REV	DESCRIPTION	DATE	APPROVED
A	CHANGED MTG LEGS TO SQUARE TUBE	04/24/01	RJF
B	CHANGED TO FLANGE MOUNT	01/30/03	RJF
C	OVERALL HEIGHT WAS 36.00	12/18/06	RJF

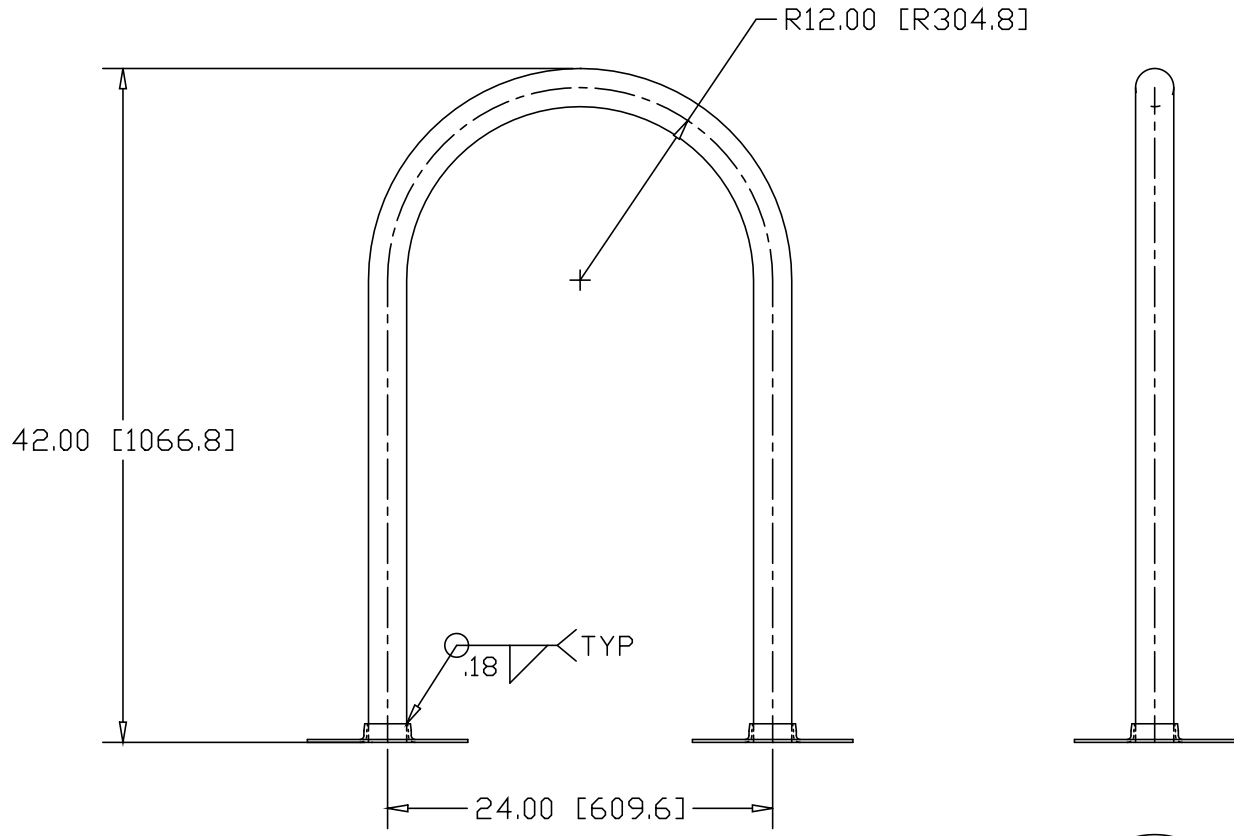

Ø10.00 [254.0] DIA FLANGE WITH (4) .50 [12.7] MOUNTING HOLES

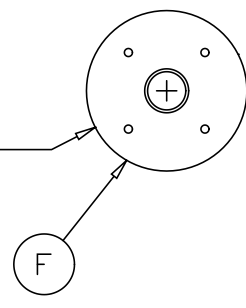

INCHES [MILLIMETERS]

ALTERNATE MATERIAL	PART NUMBER
2" SCH 40 STEEL PIPE - GALVANIZED	SR1G-SM
2" SCH 40 STAINLESS STEEL PIPE W/#4 SATIN	SR1SS-SM

PART NAME SINGLE LOOP BIKE RACK W/SURFACE MOUNT					
MATERIAL 2" SCH 40 (2.38" O.D.) A53 STEEL PIPE					
DATE	12/23/97	 <b>THE WAGNER COMPANIES</b> R & B WAGNER, INC. AND J. G. BRAUN CO.			
DRAWN BY	RJF				
FINISH	MILL				
SIZE	A	WEIGHT	33 LBS	PART NUMBER	SR1M-SM
				REV	C