

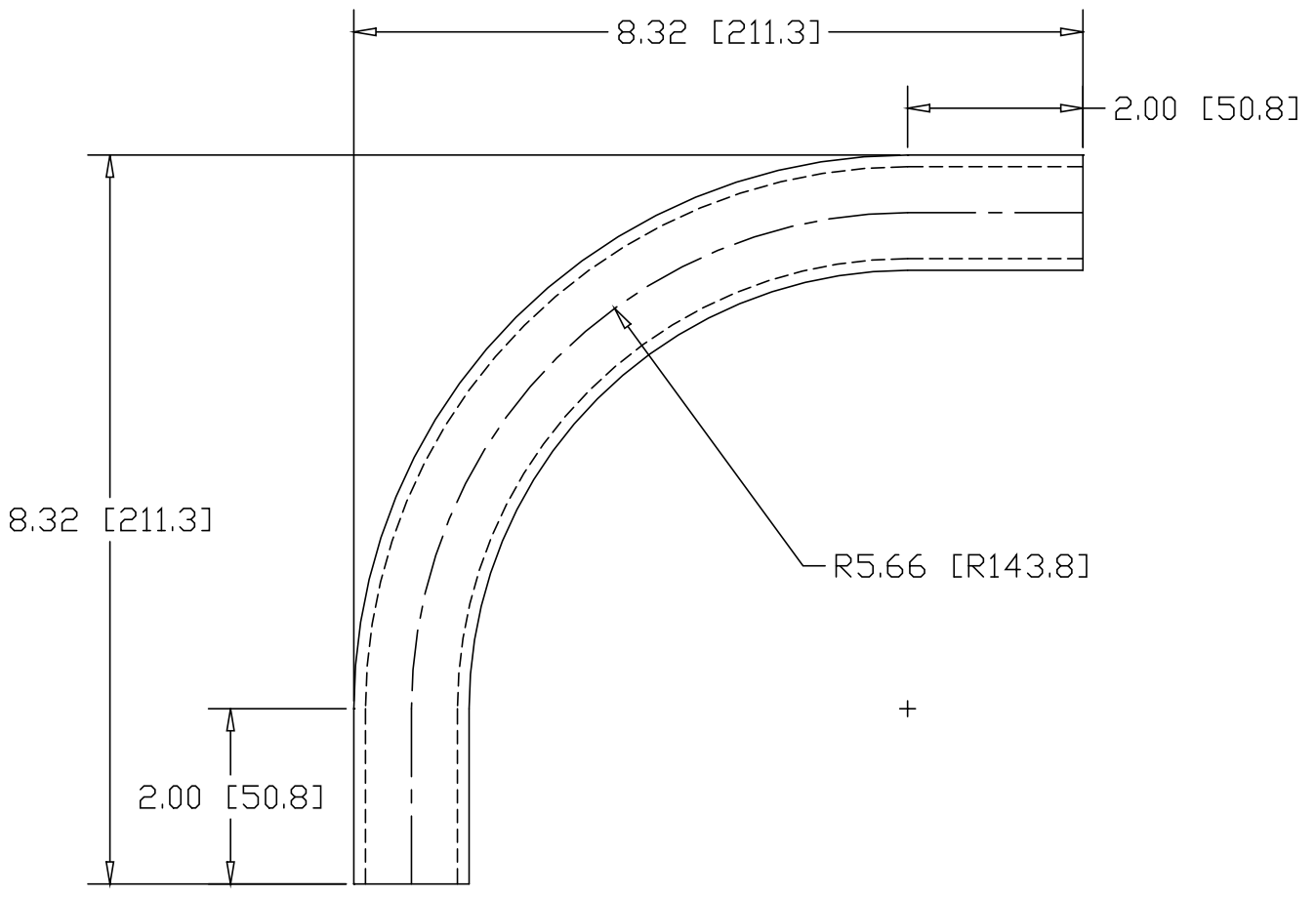

REV
SH
7009
DWG NO

REVISIONS			
REV	DESCRIPTION	DATE	APPROVED



INCHES [MILLIMETERS]

ALTERNATE MATERIAL	PART NUMBER
1" SCH 40 (6063) ALUMINUM PIPE	7029
1" SCH 40 (304) STAINLESS STEEL PIPE	7049

PART NAME 1" PIPE SIZE 90° ELL X 5" I.R. W/ (2) 2" TANGENTS			
MATERIAL 1" SCH 40 A53 STEEL PIPE			
DATE 4/30/96		R & B WAGNER, INC.	
DRAWN BY RJF		SIZE A	WEIGHT 1.79 LBS
FINISH MILL		PART NUMBER 7009	REV