

REV
SH
1622-T
DWG NO

REVISIONS			
REV	DESCRIPTION	DATE	APPROVED

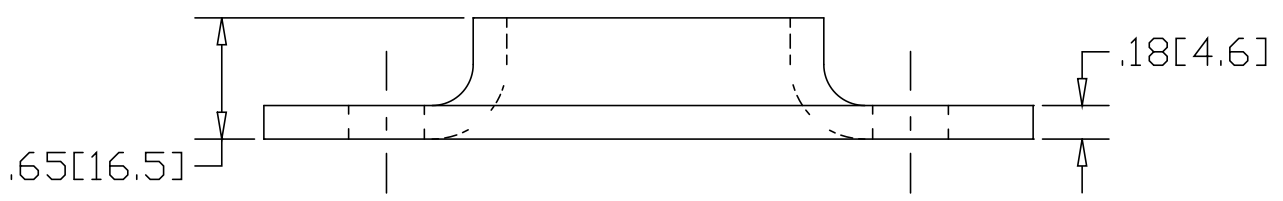
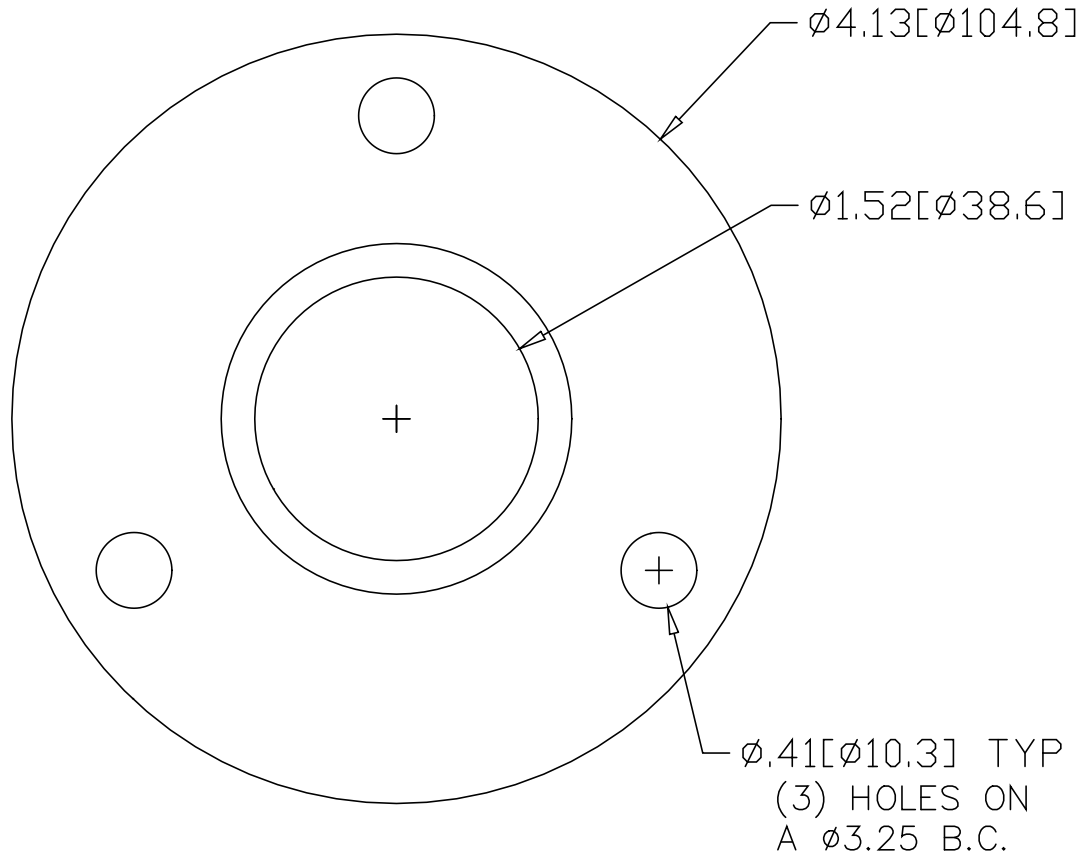

INCHES [MILLIMETERS]

*USE WITH ANCHOR PLATE
#B1608 IN STEEL
#B1658 IN ALUMINUM

ALTERNATE MATERIAL	PART NUMBER
.190" (3003) ALUMINUM ASTM B-209	1642-T

PART NAME 1.50" O.D. TUBE EXTRA HEAVY FLANGE W/(3) HOLES			
MATERIAL 7 GA. HRP&O STEEL ASTM A-569			
DATE 3/6/95		R & B WAGNER, INC.	
DRAWN BY RJF		PART NUMBER 1622-T	REV
FINISH MILL	SIZE A	WEIGHT .62 LBS	