

REV  
SH  
3750  
DWG NO

REVISIONS			
REV	DESCRIPTION	DATE	APPROVED

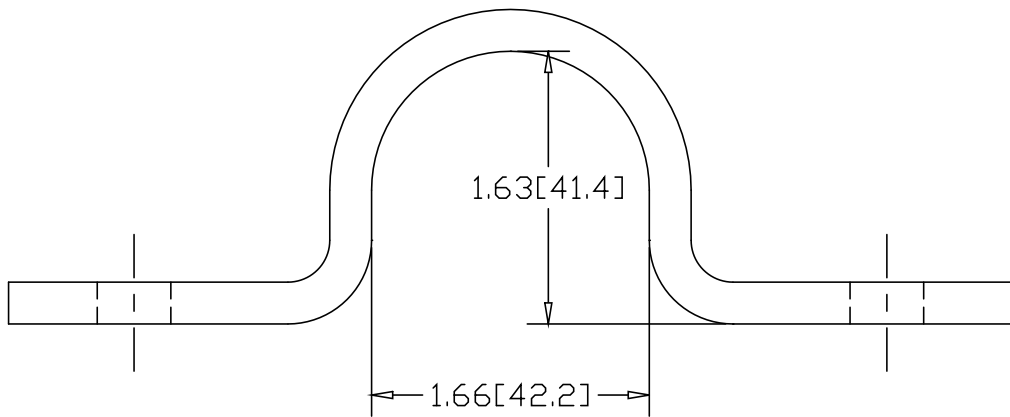
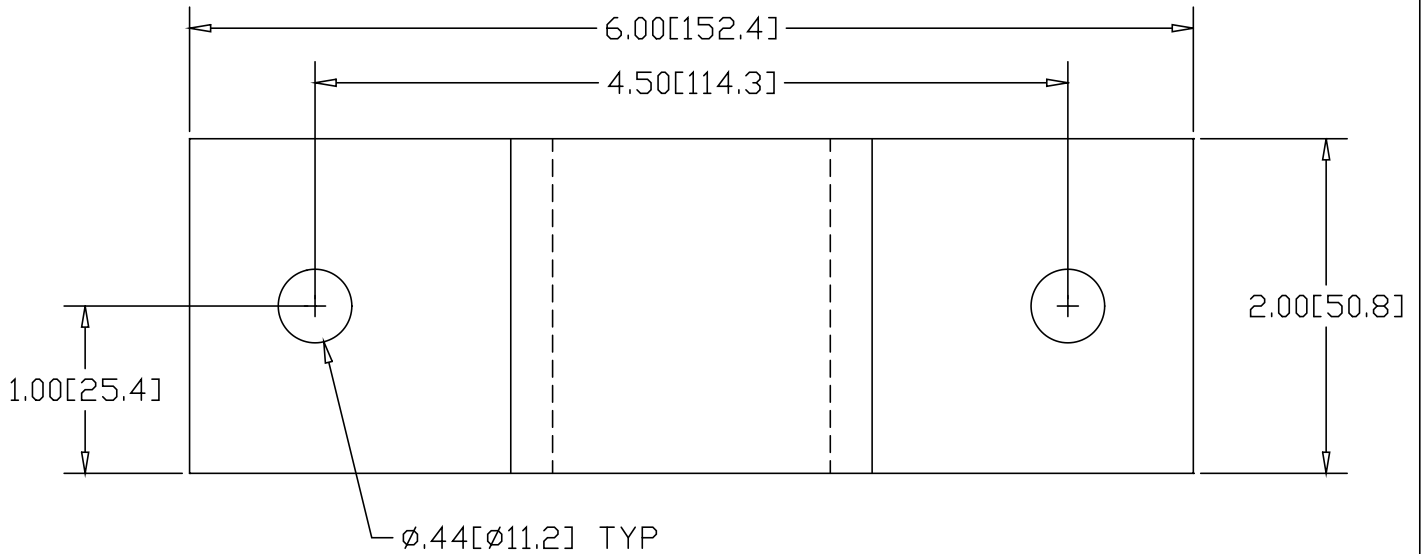

INCHES [MILLIMETERS]

ALTERNATE MATERIAL	PART NUMBER
.250 (3003) ALUMINUM ASTM B209	3756
7 GA. (304) STAINLESS STEEL ASTM A240	3762-SS

PART NAME 1-1/4" PIPE (1.66" OD) X 2" WIDE U-BRACKET W/(2) HOLES

MATERIAL .250 HRP&□ STEEL ASTM A569

DATE 1/13/00

DRAWN BY RJF

FINISH

MILL



**THE WAGNER COMPANIES**  
R & B WAGNER, INC. AND J. G. BRAUN CO.

SIZE	WEIGHT	PART NUMBER	REV
A	1.02 LBS	3750	