

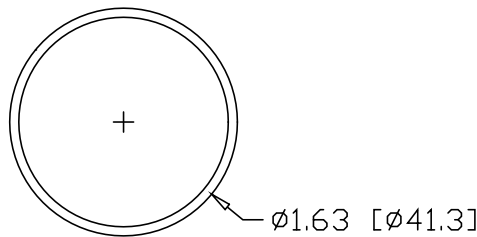

REV  
SH  
7906T  
DWG NO

REVISIONS			
REV	DESCRIPTION	DATE	APPROVED

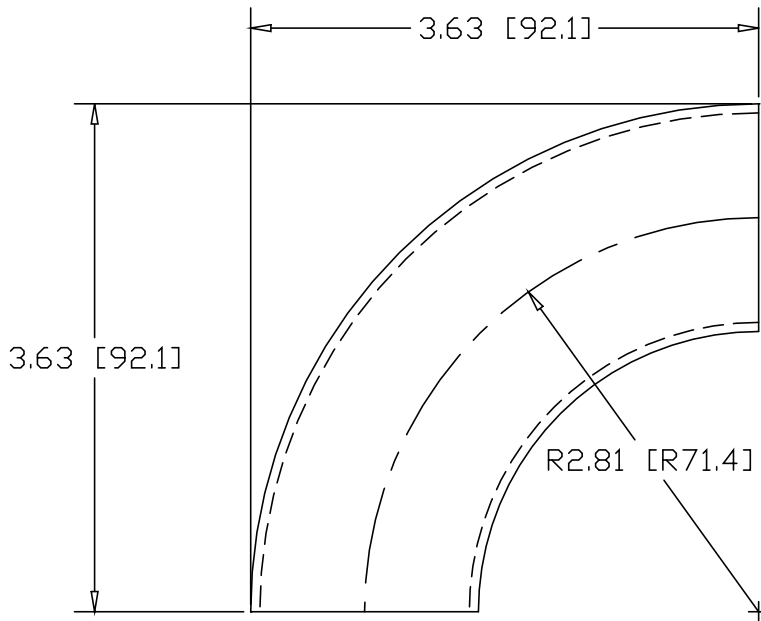

INCHES [MILLIMETERS]

ALTERNATE MATERIAL	PART NUMBER
1.63" O.D. X .125W (6061-T1) ALUMINUM TUBE	7922T
1.63" O.D. X .065W (304) STAINLESS STEEL TUBE	7938T

PART NAME		1.63" O.D. TUBE 90° ELL X 2.81 CLR					
MATERIAL		1.63" O.D. X .065W STEEL TUBE					
DATE	8/21/00	 <b>R &amp; B WAGNER, INC.</b>					
DRAWN BY	RJF						
FINISH	MILL						
SIZE	A	WEIGHT	.40 LBS	PART NUMBER	7906T	REV	