

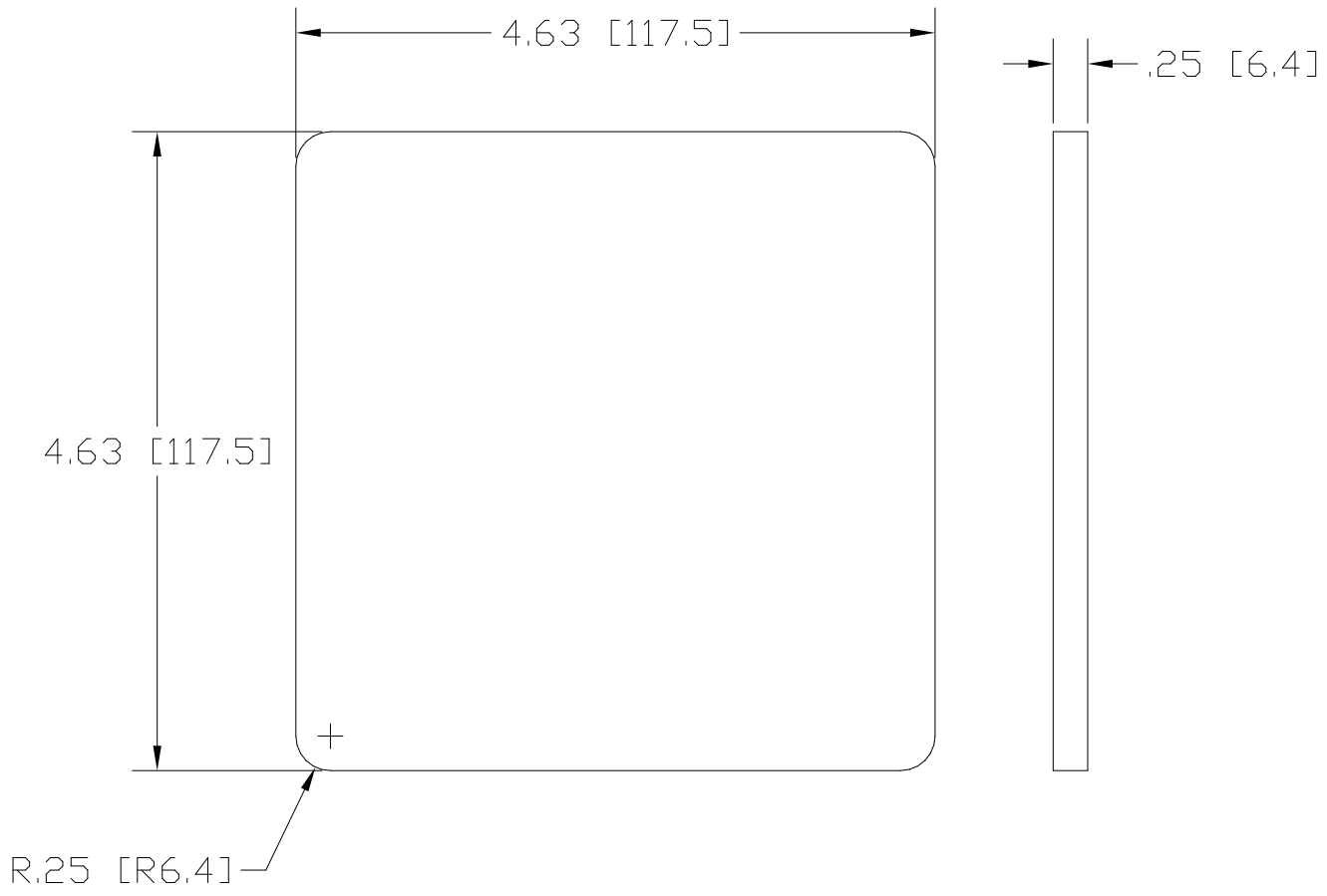

REV
SH
D484
DWG NO

REVISIONS			
REV	DESCRIPTION	DATE	APPROVED



INCHES [MILLIMETERS]

ALTERNATE MATERIAL	PART NUMBER
.250 (3003) ALUMINUM ASTM B209	D485
.18 (304) STAINLESS STEEL ASTM A240	D486
.250 (260) BRASS ASTM B19,B36	D487

PART NAME		4-5/8" SQUARE PLATE WITH RADIUS CORNERS			
MATERIAL		.250 HRP&O STEEL ASTM A569			
DATE	11/20/98	 THE WAGNER COMPANIES R & B WAGNER, INC. AND J. G. BRAUN CO.			
DRAWN BY	RJF				
FINISH	MILL				
SIZE	A	WEIGHT	1.80 LBS	PART NUMBER	D484
				REV	