

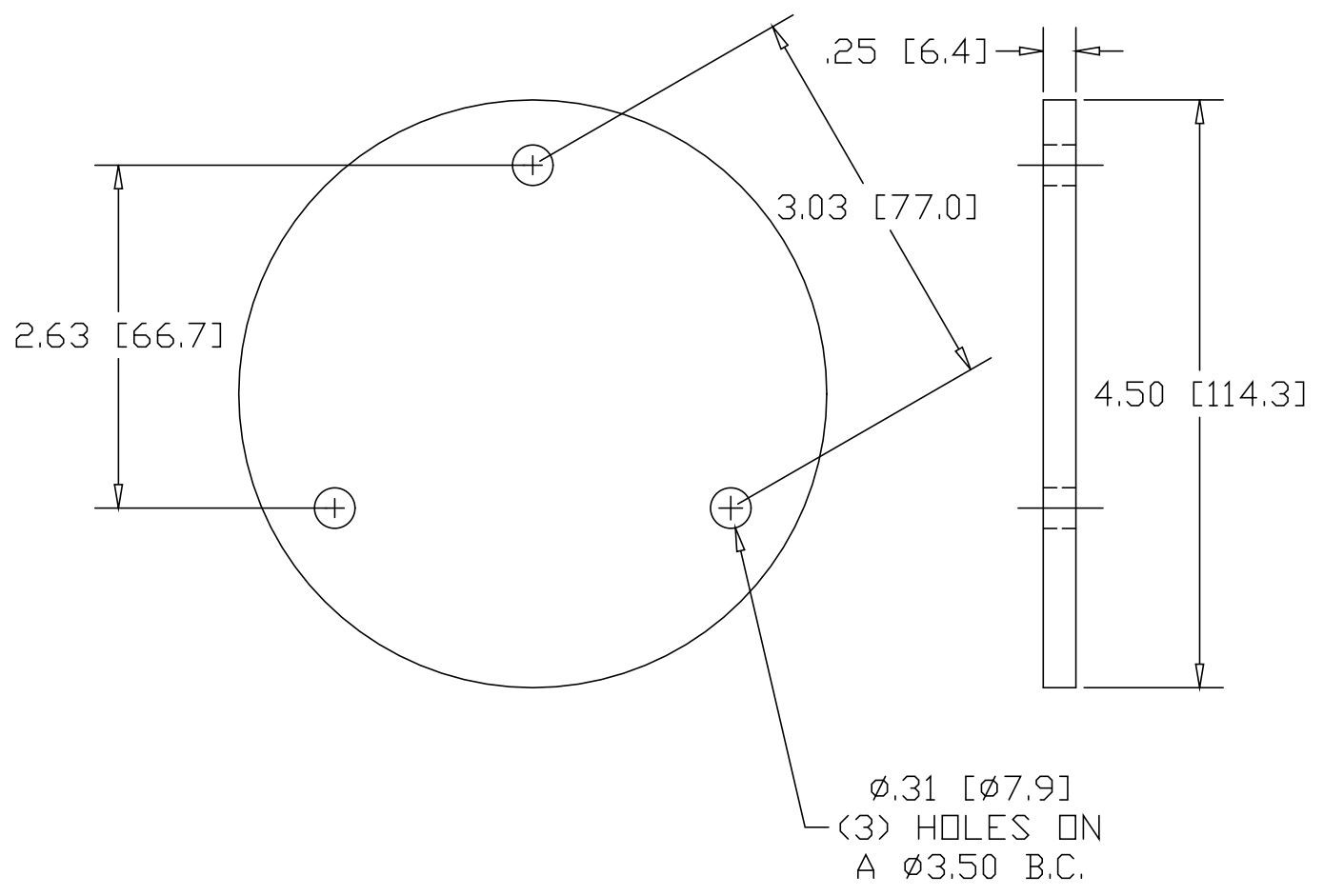

REV  
SH  
D246H  
DWG NO

REVISIONS			
REV	DESCRIPTION	DATE	APPROVED



INCHES [MILLIMETERS]

ALTERNATE MATERIAL	PART NUMBER
.250 (3003) ALUMINUM ASTM B209	D247H
.250 (304) STAINLESS STEEL ASTM A240	D248H

PART NAME				4.50" BASE DISK WITH (3) MTG HOLES	
MATERIAL				.250 HRP&D STEEL ASTM A569	
DATE	11/20/98	 <b>THE WAGNER COMPANIES</b> R & B WAGNER, INC. AND J. G. BRAUN CO.			
DRAWN BY	RJF				
FINISH	MILL				
SIZE	A	WEIGHT	.94 LBS	PART NUMBER	D246H
				REV	