

REV  
SH  
8908  
DWG NO

REVISIONS			
REV	DESCRIPTION	DATE	APPROVED

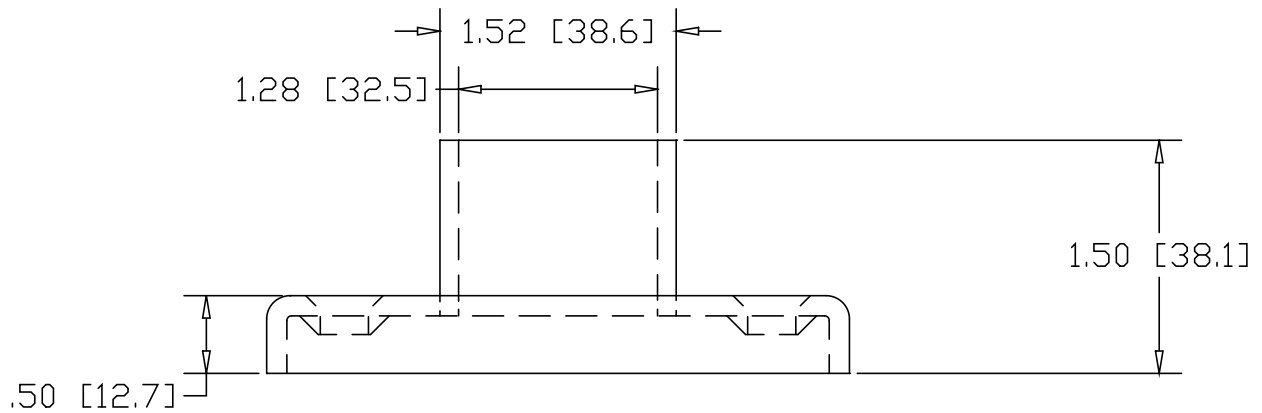
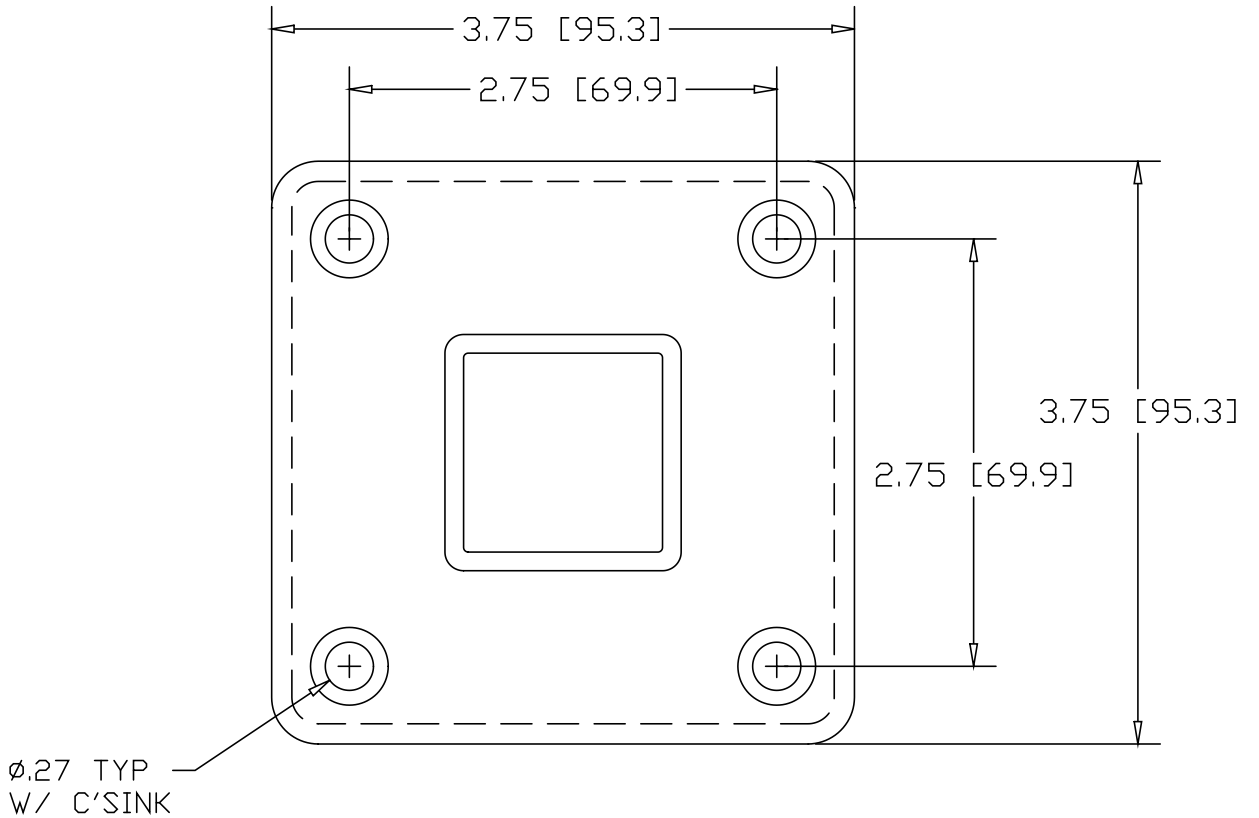

INCHES [MILLIMETERS]

ALTERNATE MATERIAL	PART NUMBER
.125 (3003) ALUMINUM ASTM B-209	8932

PART NAME 1-1/4" SQUARE TUBE SOCKET FLANGE W/⟨4⟩ HOLES			
MATERIAL 10 GA. HRP&D STEEL ASTM A-569			
DATE 3/16/95	<b>WAGNER</b>	R & B WAGNER, INC.	
DRAWN BY RJF			
FINISH MILL	SIZE A	WEIGHT .65 LBS	PART NUMBER 8908
			REV