

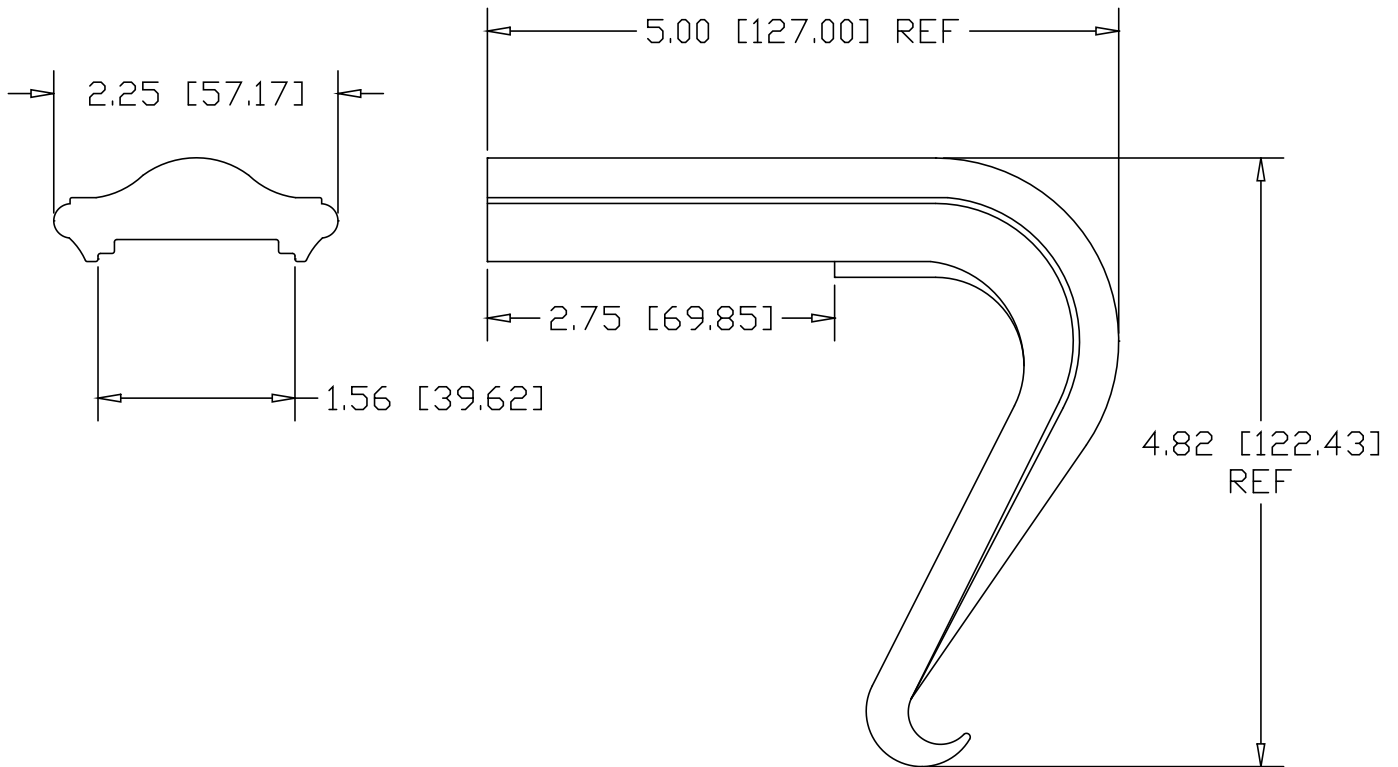

REV  
SH  
DWG NO H1244P

REVISIONS			
REV	DESCRIPTION	DATE	APPROVED



INCHES [MILLIMETERS]

PART NAME LAMB'S TONGUE STRAIGHT TERMINAL END FOR H1244			
MATERIAL MALLEABLE IRON ASTM A47			
DATE 10/01/04		<b>THE WAGNER COMPANIES</b> R & B WAGNER, INC. AND J. G. BRAUN CO.	
DRAWN BY RJF			
FINISH SHOT BLASTED			
SIZE A	WEIGHT 2.68 LBS	PART NUMBER H1244P	REV