

.06 X .10 Chamfer
Both Ends TYP

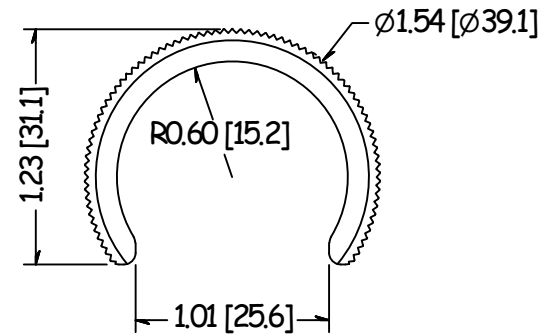

TOLERANCE	CUT LENGTH:	FINISH:	DESCRIPTION:
UNLESS OTHERWISE NOTED, TOLERANCES TO CONFORM TO ES.03.011	DEVELOPED LENGTH:	MILL	INTERNAL SLEEVE FOR 1.66" O.D. CAPRAIL
	TOOL NUMBER:	WEIGHT:	MATERIAL: Aluminum
		0.19 lbmass	MATERIAL DESC: 6005-T5 ALUMINUM

REVISION HISTORY		
REV	DESCRIPTION	DATE
1	Re-Drawn to Extrusion	04/09/2007

DATE: 1/19/2018	REV: 1	 10600 W Brown Deer Rd Milwaukee, WI 53224 COLLABORATIVE METALWORKS http://www.wagnercompanies.com/
DRAWN BY: B. Leasure	PART NUMBER: GR3166S	

2

1

B

B

A

A

2

1