

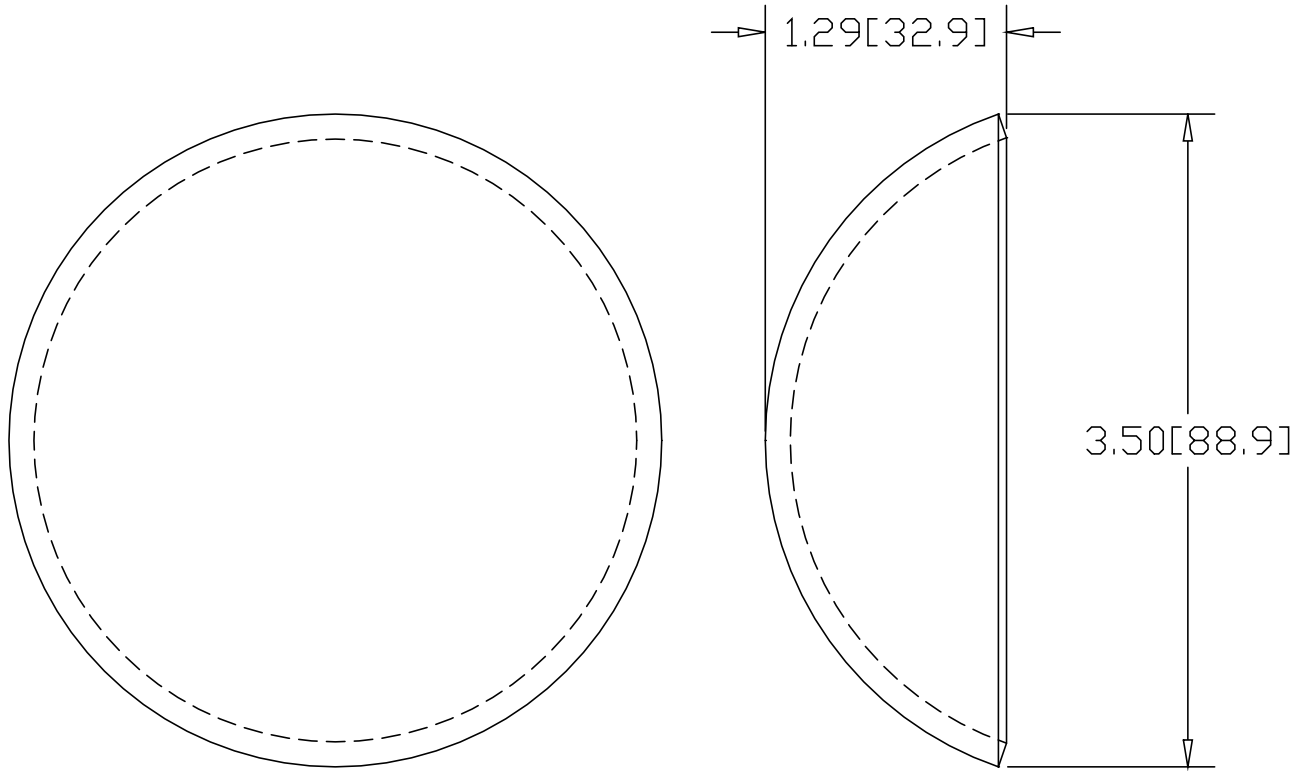

REV
SH
3225
DWG NO

REVISIONS			
REV	DESCRIPTION	DATE	APPROVED



INCHES [MILLIMETERS]

ALTERNATE MATERIAL	PART NUMBER
.125 (3003) ALUMINUM ASTM B209	3245
11 GA 304 STAINLESS STEEL ASTM A240	3265
.125 (260) RED BRASS ASTM B19,B36	BRS3225

PART NAME 3" PIPE SIZE (3.50" OD) TYPE-C WELD-ON END CAP				
MATERIAL 10 GA. HRP&D STEEL ASTM A569				
DATE 10/11/96		THE WAGNER COMPANIES R & B WAGNER, INC. AND J. G. BRAUN CO.		
DRAWN BY RJF				
FINISH MILL	SIZE A	WEIGHT .55 LBS	PART NUMBER 3225	REV