

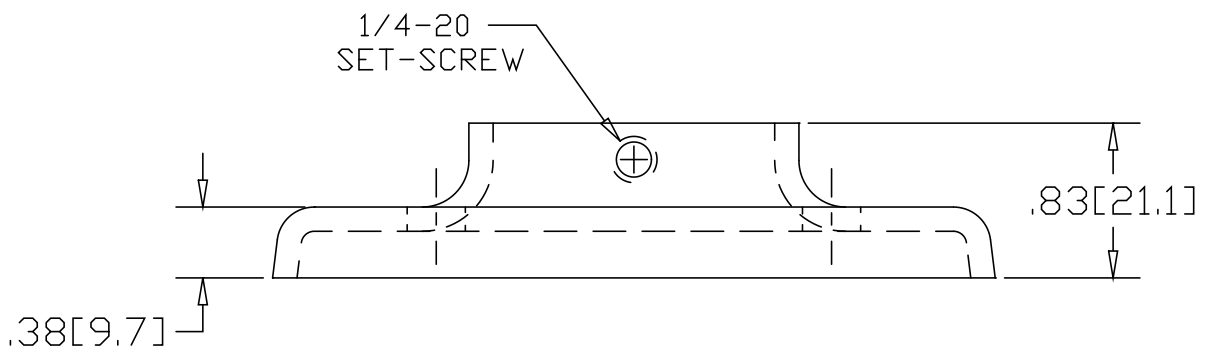

REV  
SH  
1439T  
DWG NO

REVISIONS			
REV	DESCRIPTION	DATE	APPROVED

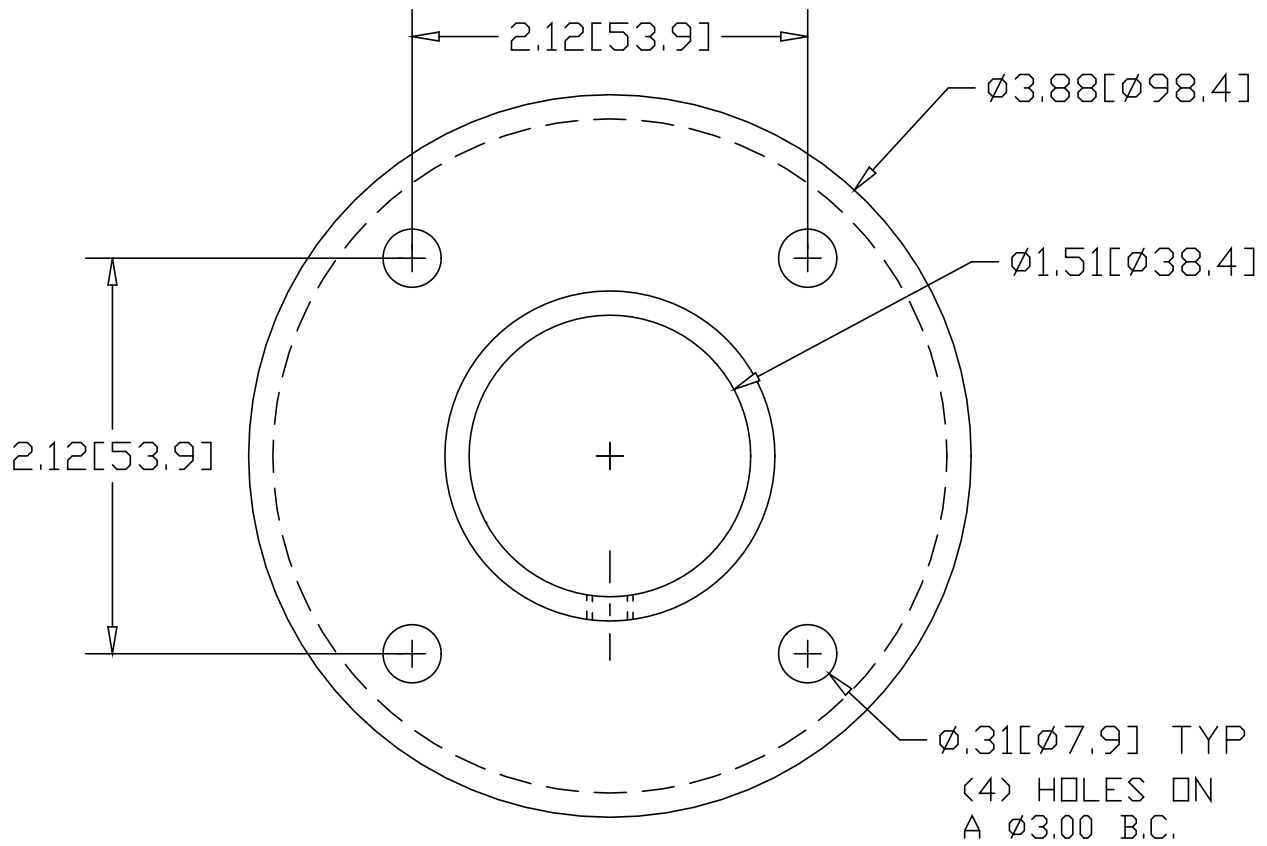

INCHES [MILLIMETERS]

ALTERNATE MATERIAL	PART NUMBER
.125 (3003) ALUMINUM ASTM B209	1479T
10 GA. (304) STAINLESS STEEL ASTM A240	1539T

PART NAME 1.50" OD TUBE HEAVY BASE FLANGE W/(4) HOLES & SET-SCREW			
MATERIAL 10 GA. HRP&D STEEL ASTM A569			
DATE 9/13/94		R & B WAGNER, INC.	
DRAWN BY RJF			
FINISH MILL		SIZE A	WEIGHT .50 LBS
			REV